

RoHS GP HF

REV.	ECN MARK	ECN NO.	DESCRIPTION	DRAWN	DATE
A	⊗	—	NEW	ZhuChao	2022/12/02

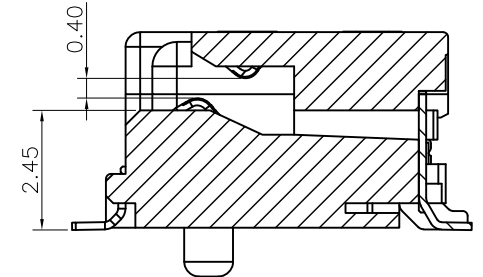

SECTION A-A 2:1

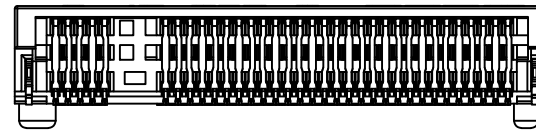
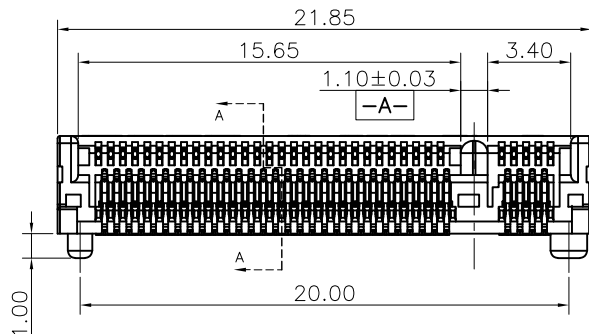
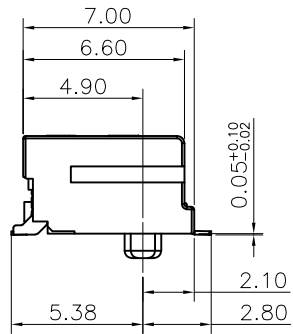
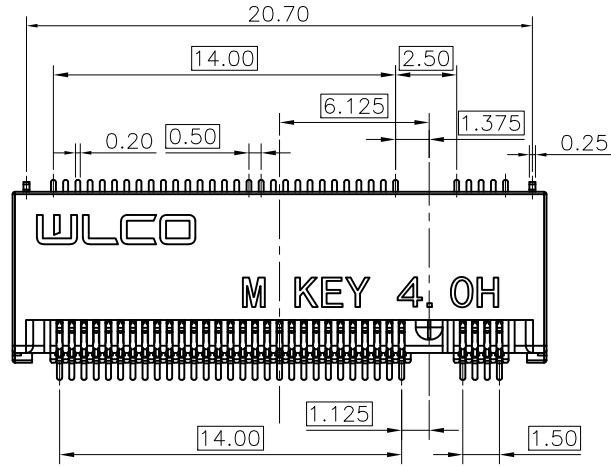
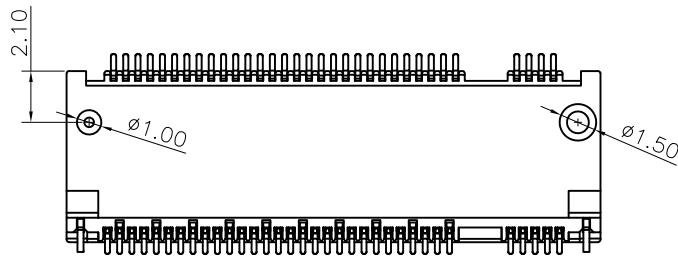

Notes:

- Ratings
  - Voltage Rating: 3.3V DC (Per pin);
  - Current Rating: 0.5A (Per pin);
  - Operating Temperature: -40°C ~ 80°C;
- Electrical Requirement:
  - LLCR: 55mΩ Max,(Initial), 20mΩ Max. change allowed(Final);
  - Dielectric Withstanding Voltage: 300V AC (RMS) for 1 minute;
  - Insulation Resistance: 500MΩ Min. @ 500V DC;
- Mechanical Requirement:
  - Insertion Force-25 N
  - Durability: 25 Cycles;
  - Vibration: No electrical discontinuity greater than 2m sec shall occur;
  - Mechanical Shock: 250G(Notebook) half sine / 6 axis  
No electrical discontinuity greater than 2m sec shall occur;
- Recommended condition for SMT soldering:  
Peak temperture shall be 260±5°C,duration 10±2 seconds.

3	HOOK	2PCS	C2680,Overall matte tin and nickel plating	
2	CONTACT	67PIN	C5210,Gilded contact area, tinned welding area	
1	HOUSING	1PCS	LCP,Black,UL94-V0	
ITEM	NAME	Q'TY	SPEC DESCRIPTION	REMARKS
TOLERANCE		MODEL NAME:	M.2 KEY M 4.0H GEN4	DRAWN:
X.X	±0.35	MODEL NO:	SEE TABLE	ZhuChao
X.XX	±0.25	UNIT:	mm	CHECKED:
X.XXX	±0.10	SCALE:	1:1	Youhua Cai
ANGLE	±2.0°	REVISION:	A	APPROVED:
		SHEET:	1/2	Youhua Cai
		DATE:	2022/12/02	
		DWG NO:	C-WLM2-67P06	
		FILE:	C	

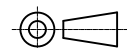

**WLCO** 深圳市兴万联电子有限公司  
SHENZHEN XING WAN LIAN ELECTRONICS CO., LTD.

RoHS GP HF

REV.	ECN MARK	ECN NO.	DESCRIPTION	DRAWN	DATE
A	⊗	—	NEW	ZhuChao	2022/12/02

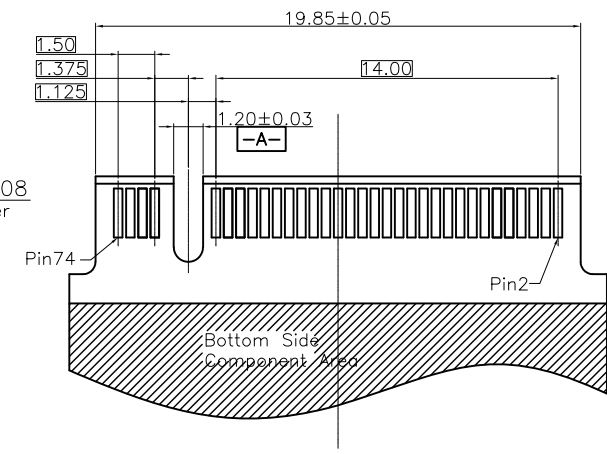
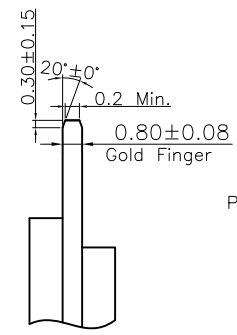
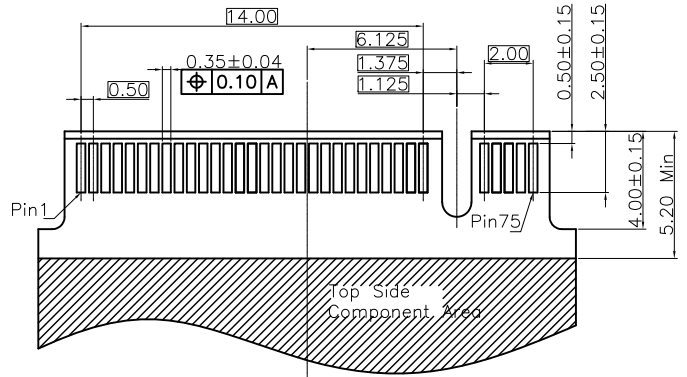

Recommended Mould Finger Layout  
Default Tolerance ±0.05

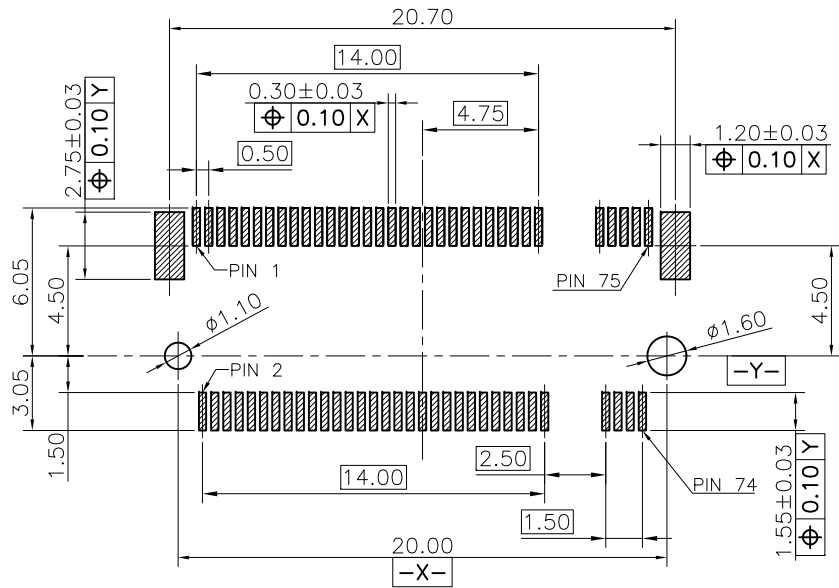

Recommended PCB Layout (Top View)  
Default Tolerance ±0.05

TABLE

NO.	PART NO	SPECIFICATION
1	WLM2-050A	HOUSING_LCP BLACK UL94-V0,CONTACT_C5210 Au 1u",Sn100u";PEG_C2680 Sn100u"

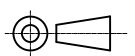
TOLERANCE X.X ±0.35 X.XX ±0.25 X.XXX ±0.10 ANGLE ±2.0°	MODEL NAME:	M.2 KEY M 4.0H GEN4	DRAWN:	ZhuChao
	MODEL NO:	SEE TABLE	CHECKED:	Youhua Cai
	UNIT:	SCALE:	REVISION:	SHEET:
	mm	1:1	A	2/2
 <b>WLCO</b> 深圳市兴万联电子有限公司 SHENZHEN XING WAN LIAN ELECTRONICS CO., LTD.	DWG NO:	C-WLM2-050A	APPROVED:	Youhua Cai
	FILE:	C	DATE:	2022/12/05