

RoHS GP HF

REV.	ECN MARK	ECN NO.	DESCRIPTION	DRAWN	DATE
A		-	NEW	Li Song	2023/03/13

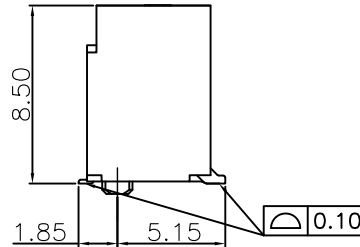
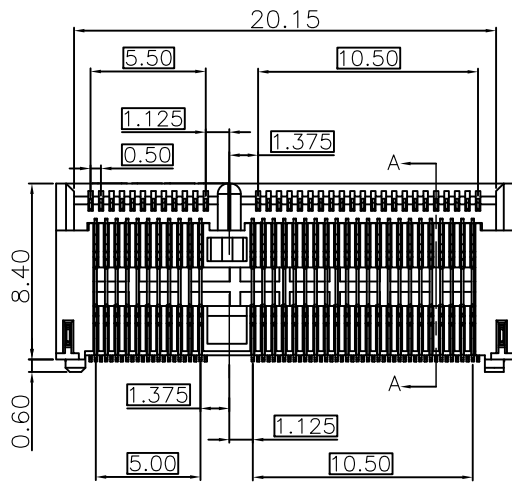
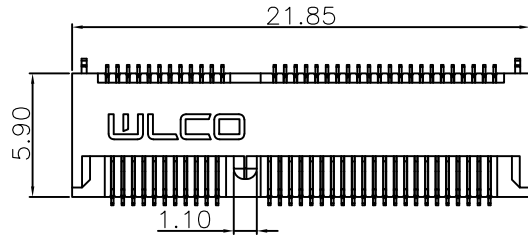

Notes:

- Materials
 - Housing: HIGH TEMPERATURE THERMOPLASTIC,UL94 V0;COLOR: BLACK;
 - Contact: COPPER ALLOY T=0.15mm, Gold Plating at mating area
 - PEG: COPPER ALLOY T=0.20mm, Matte Tin And Nickel Plating over all.
- RoHS 2.0 and HF compliant;
- Ratings
 - Voltage Rating: 30V AC (Per pin);
 - Current Rating: 0.5A (Per pin);
 - Operating Temperature: -55°C ~ 85°C;
- Electrical Requirement:
 - LLCR: 55mΩ Max,(Initial), 20mΩ Max. change allowed(Final);
 - Dielectric Withstanding Voltage: 300V AC (RMS) for 1 minute;
 - Insulation Resistance: 500MΩ Min. @ 500V DC;
- Mechanical Requirement:
 - Mating Force: 20N Max.;
 - Unmating Force: 25N Max.;
 - Durability: 30 Cycles;
- Resistance to heat: the temperature shall be 260±5°C 10±1 seconds.

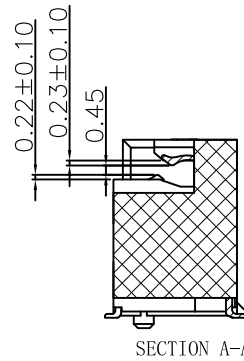
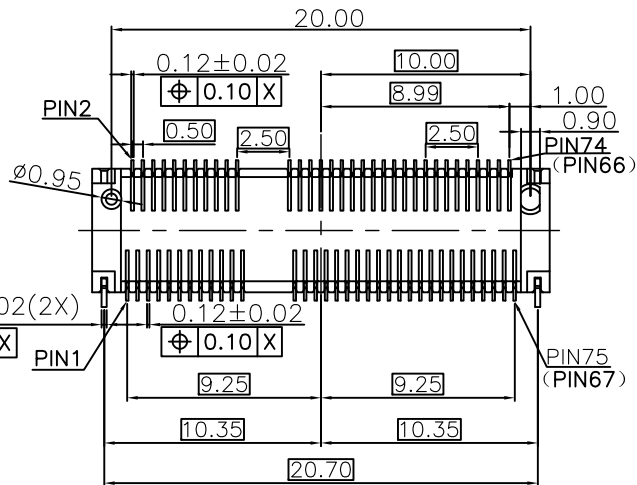

ITEM	NAME	Q'TY	SPEC DESCRIPTION	REMARKS
3	HOOK	2PCS	COPPER ALLOY,MATTE TIN AND NICKEL PLATING OVER ALL	OPTION
2	CONTACT	67PIN	COPPER ALLOY,GOLD PLATING OVER ON CONTACT AREA	OPTION
1	HOUSING	1PCS	HIGH TEMPERATURE THERMOPLASTIC,UL94-V0	OPTION

TOLERANCE X.X ±0.35 X.XX ±0.25 X.XXX ±0.10 ANGLE ±2.0°	MODEL NAME: M. 2, E-KEY, 4.0 SMT H=8.5, BLACK			DRAWN: Li Song
	MODEL NO: SEE TABLE			CHECKED: Youhua Cai
	UNIT: mm	SCALE: 1:1	REVISION: A	SHEET: 1/3
	DATE: 2023/03/13			APPROVED: Youhua Cai
DWG NO: C-WLM2-67P10			FILE: C	

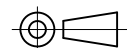

WILCO 深圳市兴万联电子有限公司
SHENZHEN XING WAN LIAN ELECTRONICS CO., LTD.

RoHS GP HF

REV.	ECN MARK	ECN NO.	DESCRIPTION	DRAWN	DATE
A		-	NEW	Li Song	2023/03/13

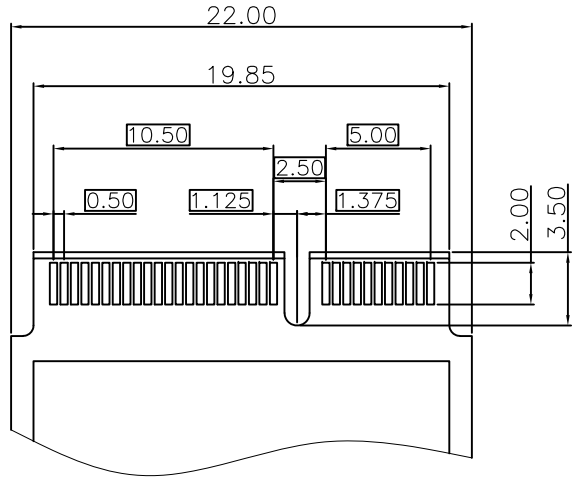

BOTTOM SIDE

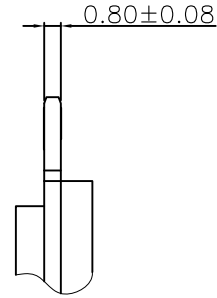

PLUG PCB

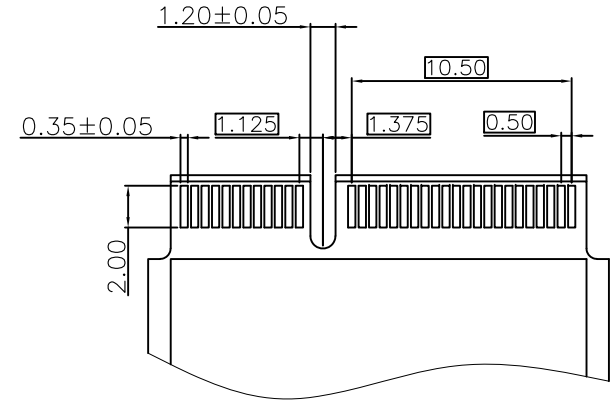

TOP SIDE

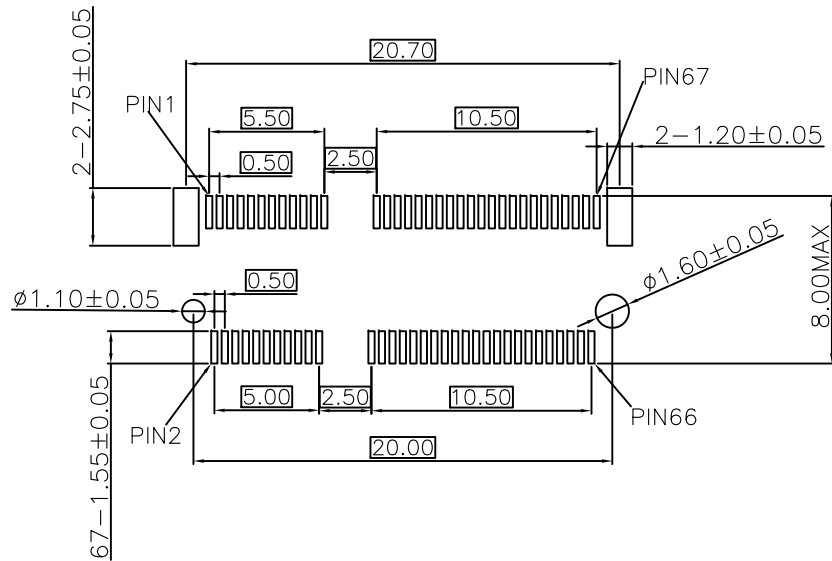

RECOMMENDED PCB LAYOUT

TABLE

NO.	PART NO	SPECIFICATION
1	WLM2-015A	HOUSING_LCP BLACK UL94-V0, CONTACT_C5210 G/F Ni50u, PEG_C2680 NICKEL PLATING
2	WLM2-016A	HOUSING_LCP BLACK UL94-V0, CONTACT_C5210 15u Ni50u, PEG_C2680 NICKEL PLATING

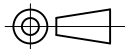
TOLERANCE X.X ±0.35 X.XX ±0.25 X.XXX ±0.10 ANGLE ±2.0°	MODEL NAME:	M. 2, E-KEY, 4.0 SMT H=8.5, BLACK	DRAWN:	Li Song		
	MODEL NO:	SEE TABLE	CHECKED:	Youhua Cai		
	UNIT:	SCALE:	REVISION:	SHEET:	APPROVED:	Youhua Cai
	mm	1:1	A	2/3	DATE:	2023/03/13
 WLCO 深圳市兴万联电子有限公司 SHENZHEN XING WAN LIAN ELECTRONICS CO., LTD.		DWG NO:	C-WLM2-67P10			
		FILE:	C			