

RoHS

GP

HF

REV.	ECR/N NO.	DESCRIPTION	DRAWN	DATE
A		NEW	WUXIAOTAO	2020/12/25
B		ADJUST DRAWING	WUXIAOTAO	2021/07/24
C		ADJUST DRAWING	WUXIAOTAO	2021/08/30

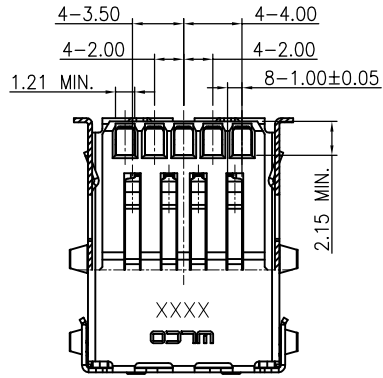
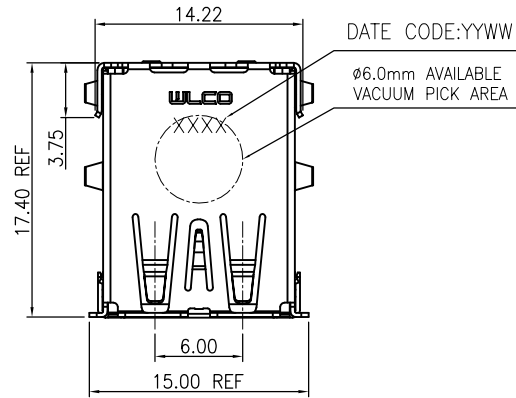

SECTION: E-E
SCALE: 1:1

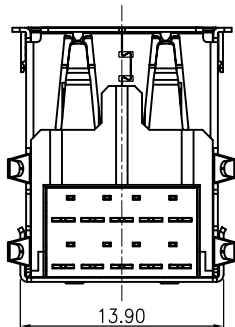
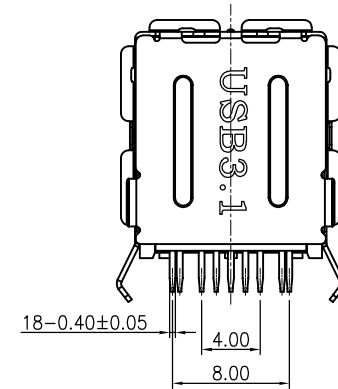
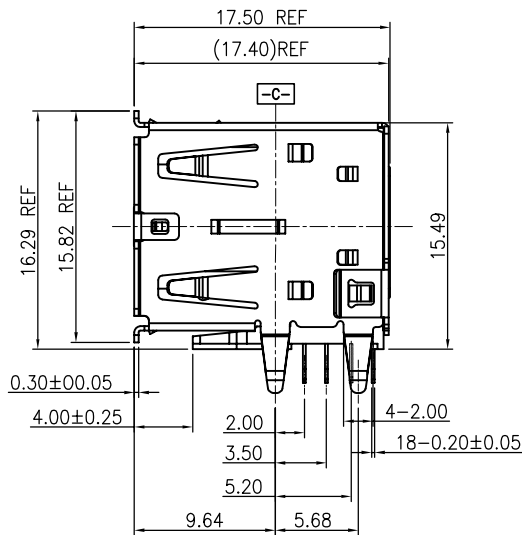
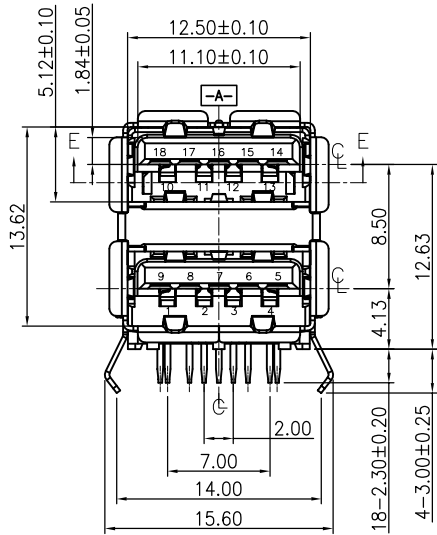
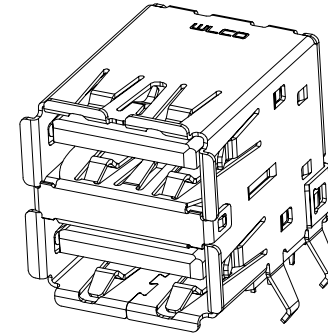

TOLERANCE	MODEL NAME: 双层USB3.1 A/F DIP 90度 PA66黑色 RoHS环保 外壳不锈钢 弯脚 脚长3.00 半金锡端子G/F 带LOGO 喷D/C 吸塑包装	DRAWN:	WUXIAOTAO
X.X ±0.35	MODEL NO: WLUS-603C	CHECKED:	WUXIAOTAO
X.XX ±0.25	UNIT: mm	APPROVED:	WUHUAMING
X.XXX ±0.10	SCALE: 1:1	DATE:	2021/08/30
ANGLE ±1.0°	REVISION: C	DWG NO:	
	SHEET 1/2	FILE:	C

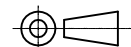

WILCO 深圳市兴万联电子有限公司
SHENZHEN XING WAN LIAN ELECTRONICS CO., LTD.

RoHS

GP

HF

REV.	ECR/N NO.	DESCRIPTION	DRAWN	DATE
A		NEW	WUXIAOTAO	2020/12/25
B		ADJUST DRAWING	WUXIAOTAO	2021/07/24
C		ADJUST DRAWING	WUXIAOTAO	2021/08/30

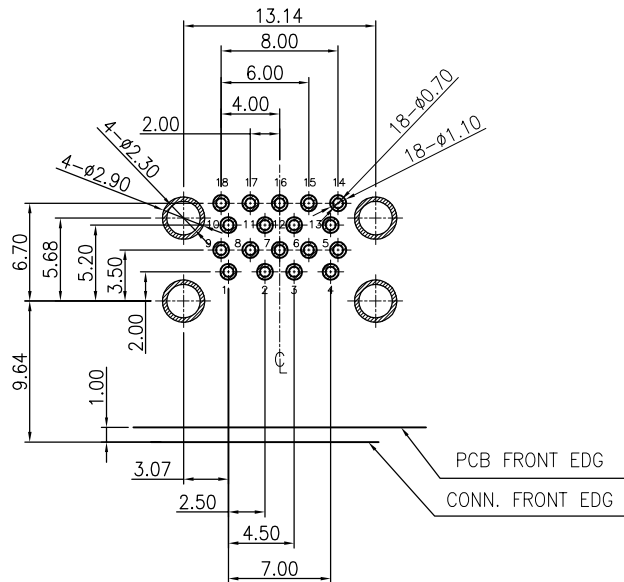

RECOMMENDED P.C.B LAYOUT
 THICKNESS:1.20mm(TOP VIEW)
 DEFAULT TOL ±0.05

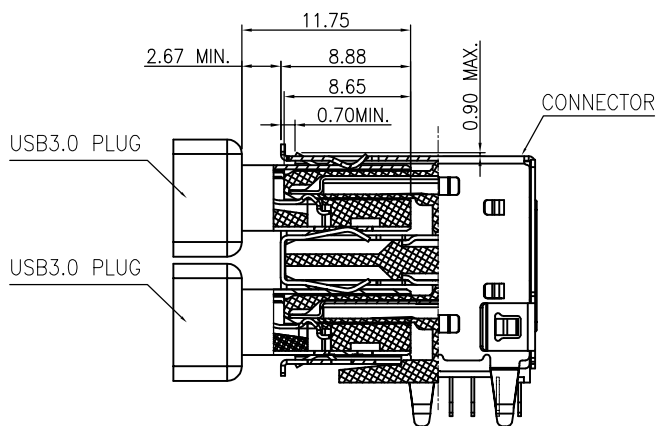

RECOMMENDED METHOD OF MATE
 SCALE 1:1

NOTE:

- MATERIAL:
 - HOUSING/COVER: THERMOPLASTIC,UL94V-0;COLOR:BLACK;
 - 4PIN CONTACTS: COPPER ALLOY,T=0.20mm;
 - 5PIN CONTACTS: COPPER ALLOY,T=0.20mm;
 - MIDDLE SHELL/OUTSIDE SHELL: STAINLESS STEEL,T=0.30mm
- PLATING SPECIFICATION:
 - CONTACTS:
 - NI 50u" MIN. PLATED ON OVERALL.
 - GOLD FLASH PLATED ON THE FUNCTIONAL AREA OF CONTACT.
 - MATTE Sn 80u" MIN. PLATED ON SOLDER AREA.
 - SHELL:
 - NI 50u" MIN. PLATED ON OVERALL.
- SPECIFICATION:
 - ELECTRICAL:
 - CONTACT CURRENT RATING: 1.8A FOR PIN1 & PIN4
 - 0.25A FOR OTHERS.
 - INSULATION RESISTANCE: 100MQ MIN.
 - CONTACT RESISTANCE: 30 mΩ MAX.
 - DIELECTRIC WITHSTANDING VOLTAGE: AC 100V FOR 1MINUTE
 - MECHANICAL:
 - INSULATION FORCE: 3.57Kgf MAX.
 - REMOVAL FORCE: 1.02Kgf MIN.,0.80Kgf MIN. AFTER DURABILITY
 - DURABILITY: 5000 CYCLES
- HF COMPLIANT.

PIN ASSIGNMENT

Pin No.	1	2	3	4	5	6	7	8	9
Pin No.	10	11	12	13	14	15	16	17	18
Signal Name	VBUS	D-	D+	GND	STDA_SSRX-	STDA_SSRX+	GND_DRAIN	STDA_SSTX-	STDA_SSTX+
Remark	USB 2.0 Contact Pin				USB 3.0 Contact Pin(GEN2 10G)				
TOLERANCE	MODEL NAME: 双层USB3.1 A/F DIP 90度 PAGE黑色 RoHS环保 外壳不锈钢 弯脚 脚长3.00 半金锡端子G/F 带LOGO 喷D/C 吸塑包装						DRAWN: WUXIAOTAO		
X.X ±0.35	MODEL NO: WLUS-603C						CHECKED: WUXIAOTAO		
X.XX ±0.25	UNIT: mm		SCALE: 1:1		REVISION: C		SHEET: 2/2		APPROVED: WUHUAMING
X.XXX ±0.10									DATE: 2021/08/30
ANGLE ±1.0°	DWG NO:						FILE: C		

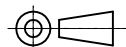

WLCO 深圳市兴万联电子有限公司
 SHENZHEN XING WAN LIAN ELECTRONICS CO.,LTD.