

RoHS GP HF

| REV. | ECR/N NO. | DESCRIPTION | DRAWN | DATE |
|------|-----------|-------------|------------|------------|
| A | / | NEW | YAOSHIXUAN | 2020/04/23 |

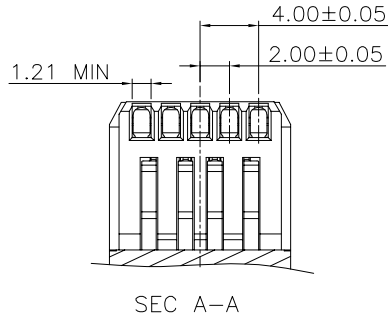
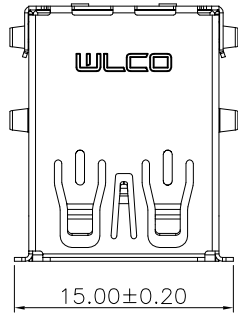

| Pin # | SIGNAL NAME | DESCRIPTION | MATING SEQUENCE |
|-------|-------------|--|-----------------|
| 1 | VBUS | POWER | SECOND |
| 2 | D- | USB 2.0 DIFFERENTIAL PAIR | THIRD |
| 3 | D+ | | |
| 4 | GND | GROUND FOR POWER RETURN | SECOND |
| 5 | StdA_SSRX- | SUPERSPEED RECEIVER DIFFERENTIAL PAIR | LAST |
| 6 | StdA_SSRX+ | | |
| 7 | GND_DRAIN | GROUND FOR SIGNAL RETURN | |
| 8 | StdA_SSTX- | SUPERSPEED TRANSMITTER DIFFERENTIAL PAIR | |
| 9 | StdA_SSTX+ | | |
| Shell | Shield | CONNECTOR METAL SHELL | FRIST |

- NOTES:
- MATERIAL:
HOUSING: PA9T COLOR: RED 1795C.
COVER: PA9T COLOR: RED 1795C.
CONTACT: C2680 T=0.20mm.
SHELL: SUS304 T=0.25mm.
MIDDLE SPRING: SUS304 T=0.20mm.
 - FINISH:
CONTACT: GOLD FLASH PLATED ON CONTACT AREA,
80u" MATTE TIN PLATED ON SOLDER TAILS,
30u" NICKEL UNDERPLATING OVER ALL.
SHELL: 40u" NICKEL PLATING OVER ALL.
 - SPECIFICATION:
3.1: ELECTRICAL:
CURRENT RATING: 1.8A FOR PIN1&PIN4;
0.25A FOR OTHERS.
INSULATION RESISTANCE: 100MΩ Min.
CONTACT RESISTANCE: 30 mΩ Max.
DIELECTRIC WITHSTANDING VOLTAGE: 100V/AC
3.2: MECHANICAL:
MATING FORCE: 3.57Kgf Max.
UNMATING FORCE: 1.0Kgf Min.
DURABILITY: 5000 CYCLES.

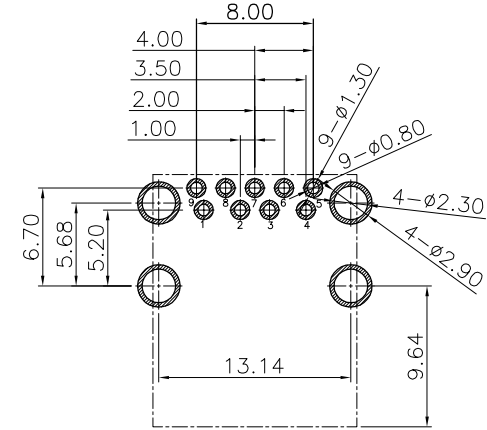
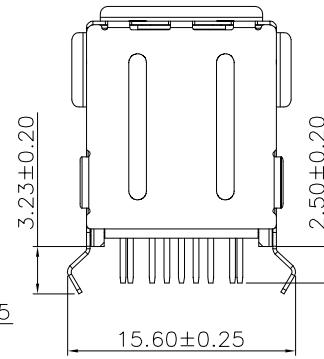
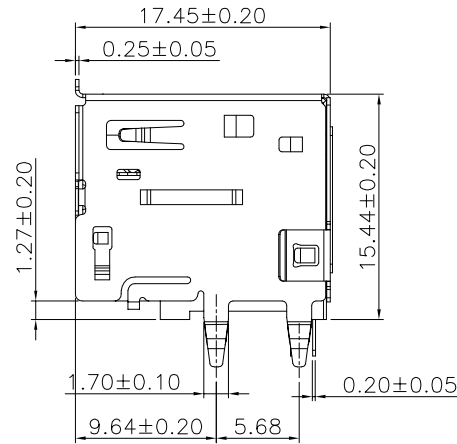
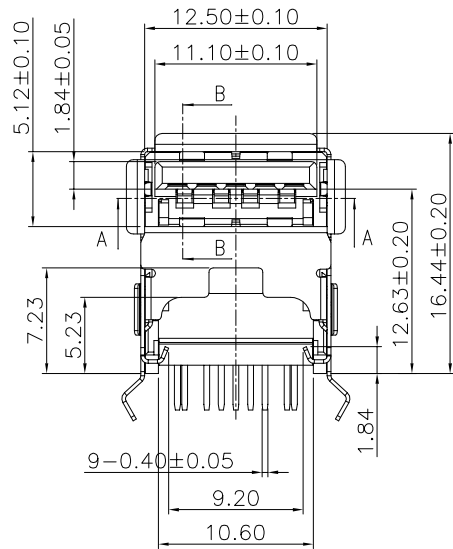

RECOMMENDED P.C.B LAYOUT(TOP VIEW)
THICKNESS 1.60mm(TOLERANCE:±0.05)

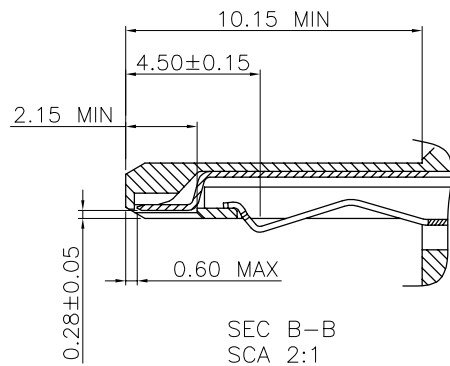
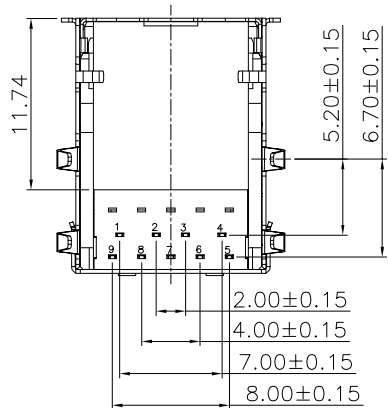

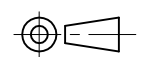
| | | | | | | |
|-------------|---|---|-----------|-------|-----------|------------|
| TOLERANCE | MODEL NAME | USB3.0 架高(下TYPE C空位) 90度DIP PA9T红色1795C SUS304外壳 端子半金锡G.F 带LOGO 吸塑包装 RoHS环保 | | | DRAWN: | DENGJU |
| X.X ±0.35 | MODEL NO: | WLUS-404F | | | CHECKED: | WUXIAOTAO |
| X.XX ±0.25 | UNIT: | SCALE: | REVISION: | SHEET | APPROVED: | WUHUAMING |
| X.XXX ±0.10 | mm | 1:1 | A | 1/1 | DATE: | 2020/04/23 |
| ANGLE ±2.0° |  WLCO 深圳市兴万联电子有限公司 SHENZHEN XING WAN LIAN ELECTRONICS CO.,LTD. | | | | DWG NO: | |
| | | | | | FILE: | C |