

RoHS GP HF

REV.	ECR/N NO.	DESCRIPTION	DRAWN	DATE
A	/	NEW	—	—
B	/	更换图框	DENGJU	2020/12/07

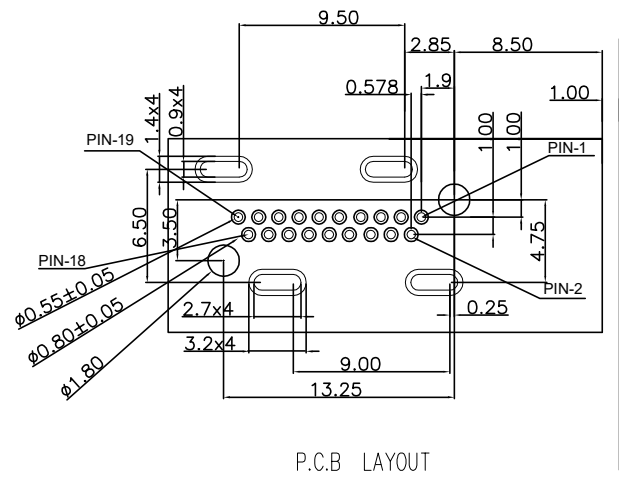
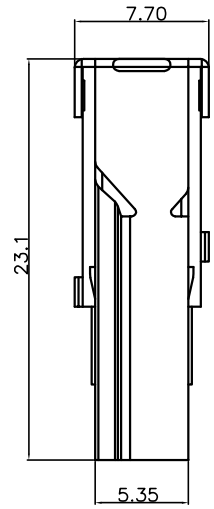

NOTE:

- MATERIAL:
HOUSING: LCP,UL94V-0; COLOR: BLACK.
CONTACT: COPPER ALLOY.
SHELL: COPPER ALLOY.
- FINISH:
CONTACT: GOLD FLASH PLATED ON CONTACT AREA,
80U" MATTE TIN PLATED ON SOLDER TAILS,
50U" NICKEL UNDERPLATING OVER ALL.
SHELL: 80U" NICKEL PLATING OVER ALL.
- SPECIFICATION:
3.1: ELECTRICAL:
CONTACT CURRENT RATING: 0.5A
INSULATION RESISTANCE: 100MΩ MIN.
CONTACT RESISTANCE: 10 mΩ MAX.
DIELECTRIC WITHSTANDING VOLTAGE: 500V/AC 1MINUTE.
3.2 MECHANICAL:
MATING FORCE: 4.5KGF MAX.
UNMATING FORCE: 1.0~4.0KGF.

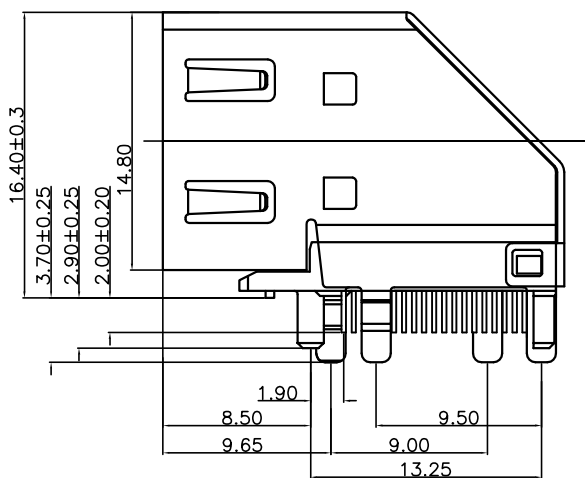
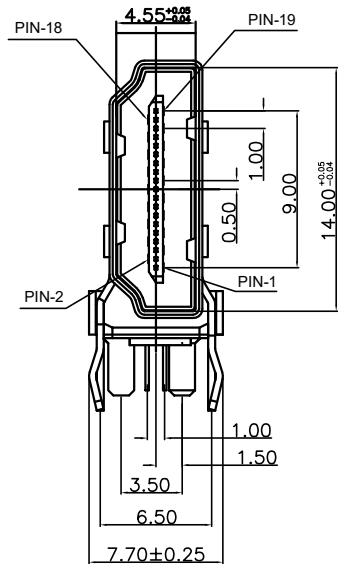

TOLERANCE	MODEL NAME: HDMI 90度 19P DIP 侧插式 LCP黑胶 端子半金雾锡G.F	DRAWN: DENGJU
X.X ±0.35	MODEL NO: WLDM-094A	CHECKED: YAOSHIXUAN
X.XX ±0.25	UNIT: mm	APPROVED: WUHUAMING
X.XXX ±0.10	SCALE: 1:1	DATE: 2020/12/07
ANGLE ±2.0°	REVISION: B	DWG NO:
	SHEET: 1/1	FILE: C
	WALCO 深圳市兴万联电子有限公司 SHENZHEN XING WAN LIAN ELECTRONICS CO.,LTD.	