

RoHS

GP

HF

REV.	ECR/N NO.	DESCRIPTION	DRAWN	DATE
A	/	NEW	HaiXiang	2017/05/24
B	/	针长由3.0±0.30改为2.7±0.30	HaiXiang	2019/11/27

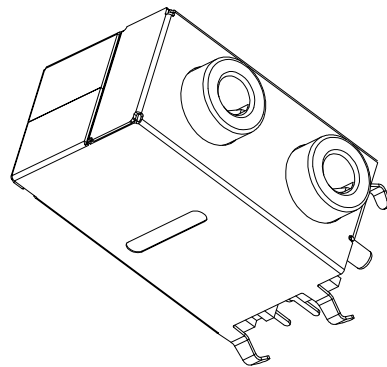
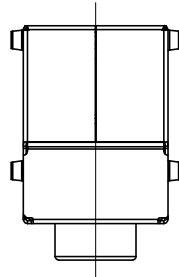

CIRCUIT DIAGRAM

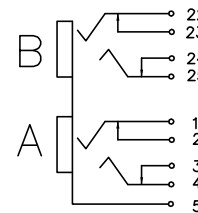

NOTES

- Electrical Characteristics:  
Contact Current Rating:1.0 Amperes.  
Dielectric Withstanding Voltage:AC 500V R.M.S.  
Insulation Resistance:100MΩ Min.  
Contact Resistance:50mΩ Max.
- Environmental:  
Operating Temperature:-25°C~+85°C.
- Material:  
See table

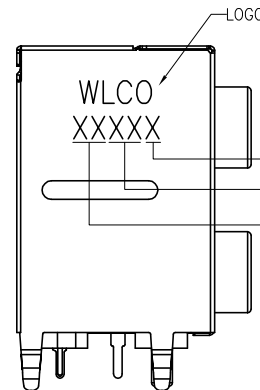
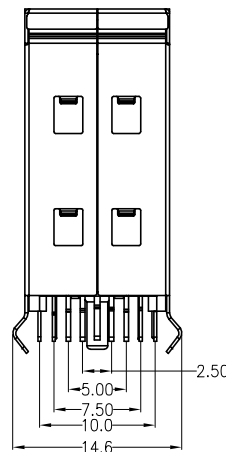
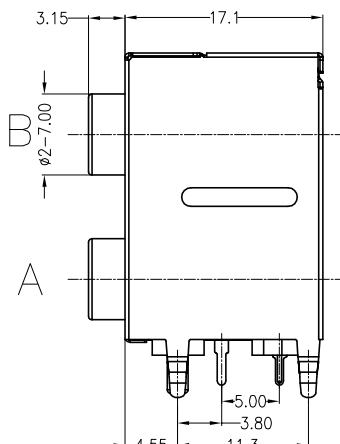
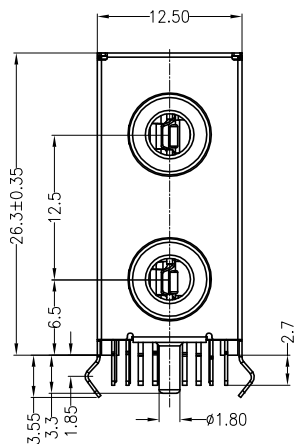

DATE CODE  
周别"1.....7"星期一~星期日  
周数:01.....52  
年数如:19=2019年

NO.	PART NAME	MATERIAL	Q' TY	PLATING
16	BACK SHELL	SPCC T=0.2mm	1	NI
15	SHELL	SPCC T=0.25mm	1	NI
14	BACK COVER	PBT (BLACK)	1	---
13	TER'-24	SPCC T=0.40mm	1	Sn
12	TER'-23	SPCC T=0.40mm	1	Sn
11	TER'-3	SPCC T=0.40mm	1	Sn
10	TER'-2	SPCC T=0.40mm	1	Sn
9	TER'-25	PHOSPHOR BRONZE T=0.25mm	1	Sn
8	TER'-22	PHOSPHOR BRONZE T=0.25mm	1	Sn
7	TER'-4	PHOSPHOR BRONZE T=0.25mm	1	Sn
6	TER'-1	PHOSPHOR BRONZE T=0.25mm	1	Sn
5	TER'-5	C2680 T=0.5mm	1	GOLD FLASH
4	BASE-B	PBT (GREEN #577C)	1	---
3	BASE-A	PBT (BLUE #284C)	1	---
2	COVER	PA46 (BLACK)	1	---
1	Housing	PBT (BLACK)	1	---

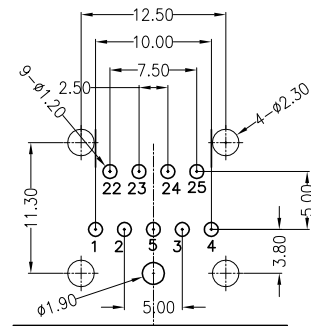
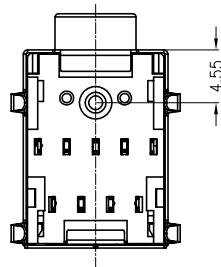

RECOMMENDED PCB LAYOUT

TOLERANCE	MODEL NAME: AUDIO JACK 1x2 上绿577C下蓝284C SPCC外壳 喷LOGO 吹膜	DRAWN: DENGJU
X.X ±0.30	MODEL NO: WLAU-021A	CHECKED: YAOSHIXUAN
X.XX ±0.25	UNIT: mm	APPROVED: WUHUAMING
X.XXX ±0.15	SCALE: 1:1	DATE: 2019/11/27
ANGLE ±2.0°	REVISION: B	DWG NO:
	SHEET: 1/1	FILE: C
	 <b>WLCO</b> 深圳市兴万联电子有限公司 SHENZHEN XING WAN LIAN ELECTRONICS CO., LTD.	