

RoHS GP HF

REV.	ECR/N NO.	DESCRIPTION	DRAWN	DATE
B	_____	_____	LongQiang	20/02/18
C	_____	_____	LongQiang	20/03/30
D	_____	_____	XiaoPeng	21/11/11

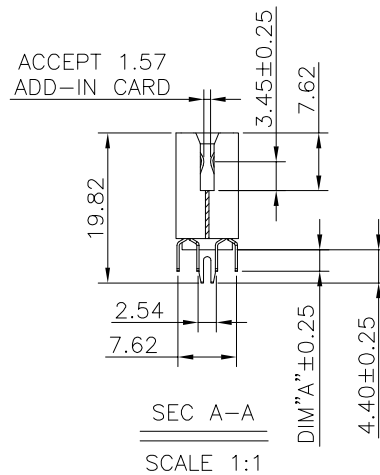
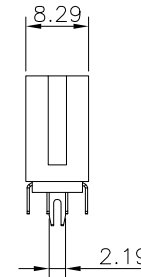
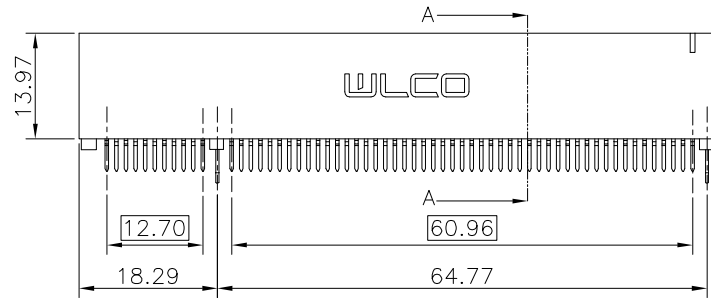
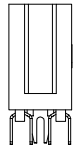
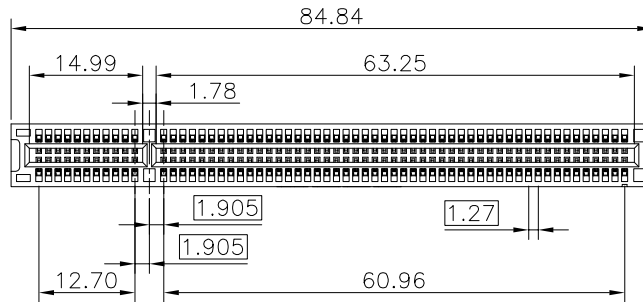

NOTES:

- MATERIAL SPECIFICATION
 - 1-1.HOUSING:HIGH TEMPERATURE THERMOPLASTIC,UL94-V0 V2 OR HB;
 - 1-2.CONTACT:COPPER ALLOY;
 - 1-3.HOOK:STEEL ALLOY OR STIANLESS STEEL OR COPPER ALLOY;
- PLATING SPECIFICATION
 - 2-1.CONTACT:
50U" MIN NICKEL UNDERPLATED;
GOLD/NICKEL PLATING ON THE CONTACT AREA;
100U" MIN MATTE TIN PLATING ON THE SOLDER AREA;
 - 2-2.HOOK:
ONLY NICKEL PLATING;
OR NO PLATING;
OR 50U" MIN NICKEL UNDERPLATED,100U" MIN MATTE TIN ;
- MECHANICAL PERFORMANCE
 - 3-1.INSERTION FORCE-MODULE TO CONNECTOR:230gf MAX(PER PAIR PIN);
 - 3-2.UNMATING FORCE(PER PIN PAIR):15gf MIN;
 - 3-3.CONTACT RETENTION FORCE:460gf/PIN MIN;
- ELECTRICAL PERFORMANCE
 - 4-1.CURRENT RATING:1 AMP;
 - 4-2.VOLTAGE RATING:250V AC R.M.S;
 - 4-3.LLCR:30mΩ MAX (INITIAL);
 - 4-4.INSULATION RESISTANCE:500V DC,1000MΩ MIN;
 - 4-5.DIELECRIC WITHSTAND VOLTAGE:500V AC,NO BREAK DOWN;
- HSF COMPLIANT;

TOLERANCE	MODEL NAME:PCI 120P DOUBLE HOOK TYPE	DRAWN:	XiaoPeng.Zhang
X.X ±0.35	MODEL NO: SEE TABLE	CHECKED:	YouHua.Cai
X.XX ±0.25	UNIT: mm	APPROVED:	YouHua.Cai
X.XXX ±0.10	SCALE: 1:1	DATE:	2021/11/11
ANGLE ±1.0°	REVISION: D	DWG NO:	CUS-WLPC-120P01
	SHEET 1/3	FILE:	C

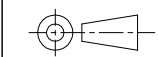

WLCO 深圳市兴万联电子有限公司
SHENZHEN XING WAN LIAN ELECTRONICS CO.,LTD.

RoHS

GP

HF

REV.	ECR/N NO.	DESCRIPTION	DRAWN	DATE
B	_____	_____	LongQiang	20/02/18
C	_____	_____	LongQiang	20/03/30
D	_____	_____	XiaoPeng	21/11/11

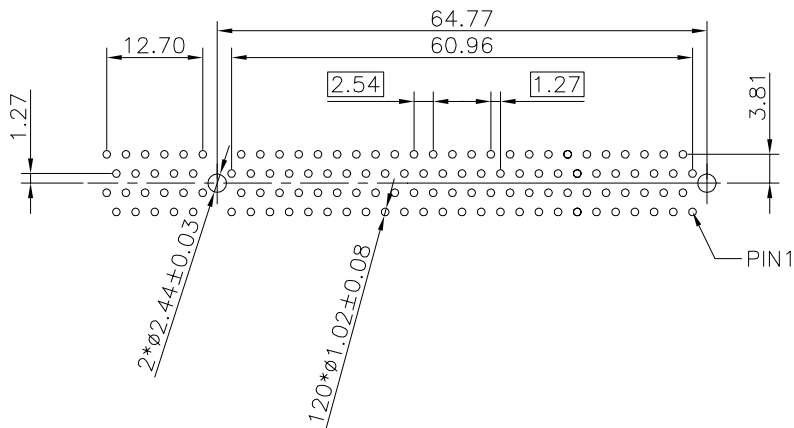

RECOMMENDED PCB LAYOUT
 DEFAULT TOLERANCE ±0.05

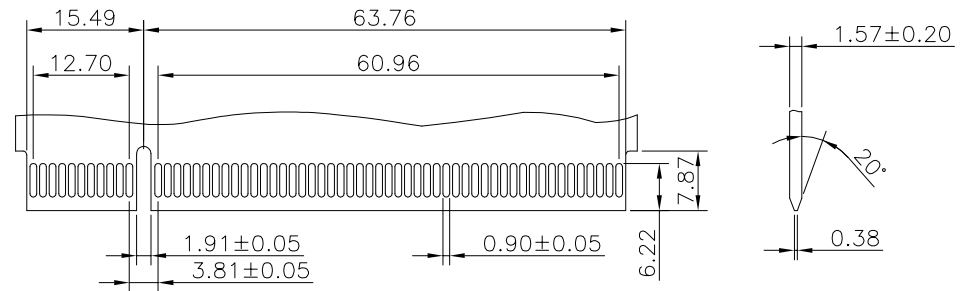

RECOMMENDED CARD EDGE FINGER
 DEFAULT TOLERANCE ±0.05

TOLERANCE	MODEL NAME:PCI 120P DOUBLE HOOK TYPE				DRAWN:	XiaoPeng.Zhang
X.X ±0.35	MODEL NO: SEE TABLE				CHECKED:	YouHua.Cai
X.XX ±0.25	UNIT:	SCALE:	REVISION:	SHEET	APPROVED:	YouHua.Cai
X.XXX ±0.10	mm	1:1	D	2/3	DATE:	2021/11/11
ANGLE ±1.0°	 WLCO 深圳市兴万联电子有限公司 SHENZHEN XING WAN LIAN ELECTRONICS CO.,LTD.				DWG NO:	CUS-WLPC-120P01
					FILE:	C

RoHS GP HF

REV.	ECR/N NO.	DESCRIPTION	DRAWN	DATE
B	_____	_____	LongQiang	20/02/18
C	_____	_____	LongQiang	20/03/30
D	_____	_____	XiaoPeng	21/11/11

TABLE

NO.	PART NO.	SPECIFICATION	HSF COMPLIANT	DIM"A"
1	WLPC-110A	HOUSING_PA66 WHITE UL94-HB, CONTACT_C2680 G/F Ni50u, HOOK_STEEL ALLOY NICKEL PLATING.	RoHS COMPLIANT	3.00mm

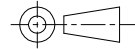
TOLERANCE X.X ±0.35 X.XX ±0.25 X.XXX ±0.10 ANGLE ±1.0°	MODEL NAME:PCI 120P DOUBLE HOOK TYPE				DRAWN: XiaoPeng.Zhang	
	MODEL NO: SEE TABLE				CHECKED: YouHua.Cai	
	UNIT:	SCALE:	REVISION:	SHEET	APPROVED: YouHua.Cai	
	mm	1:1	D	3/3	DATE: 2021/11/11	
				WLCO 深圳市兴万联电子有限公司 SHENZHEN XING WAN LIAN ELECTRONICS CO.,LTD.		DWG NO:CUS-WLPC-120P01 FILE: C