

RoHS GP HF

REV.	ECR/N NO.	DESCRIPTION	DRAWN	DATE
A	—	—	LongQiang	21/01/05
B	—	—	LongQiang	21/03/01

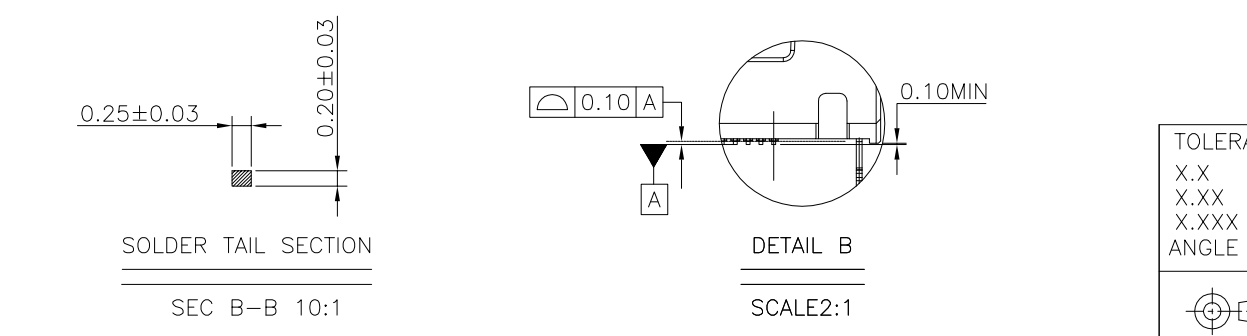
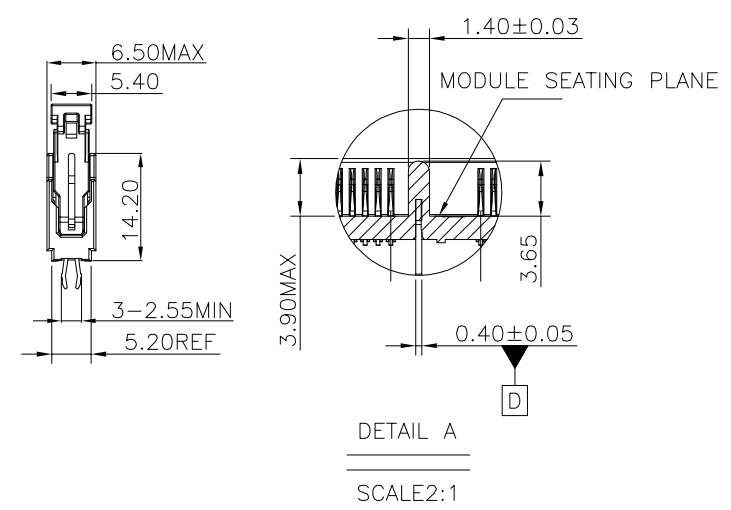
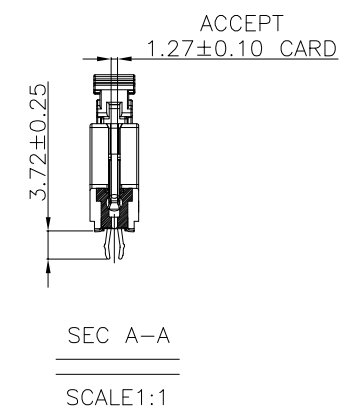
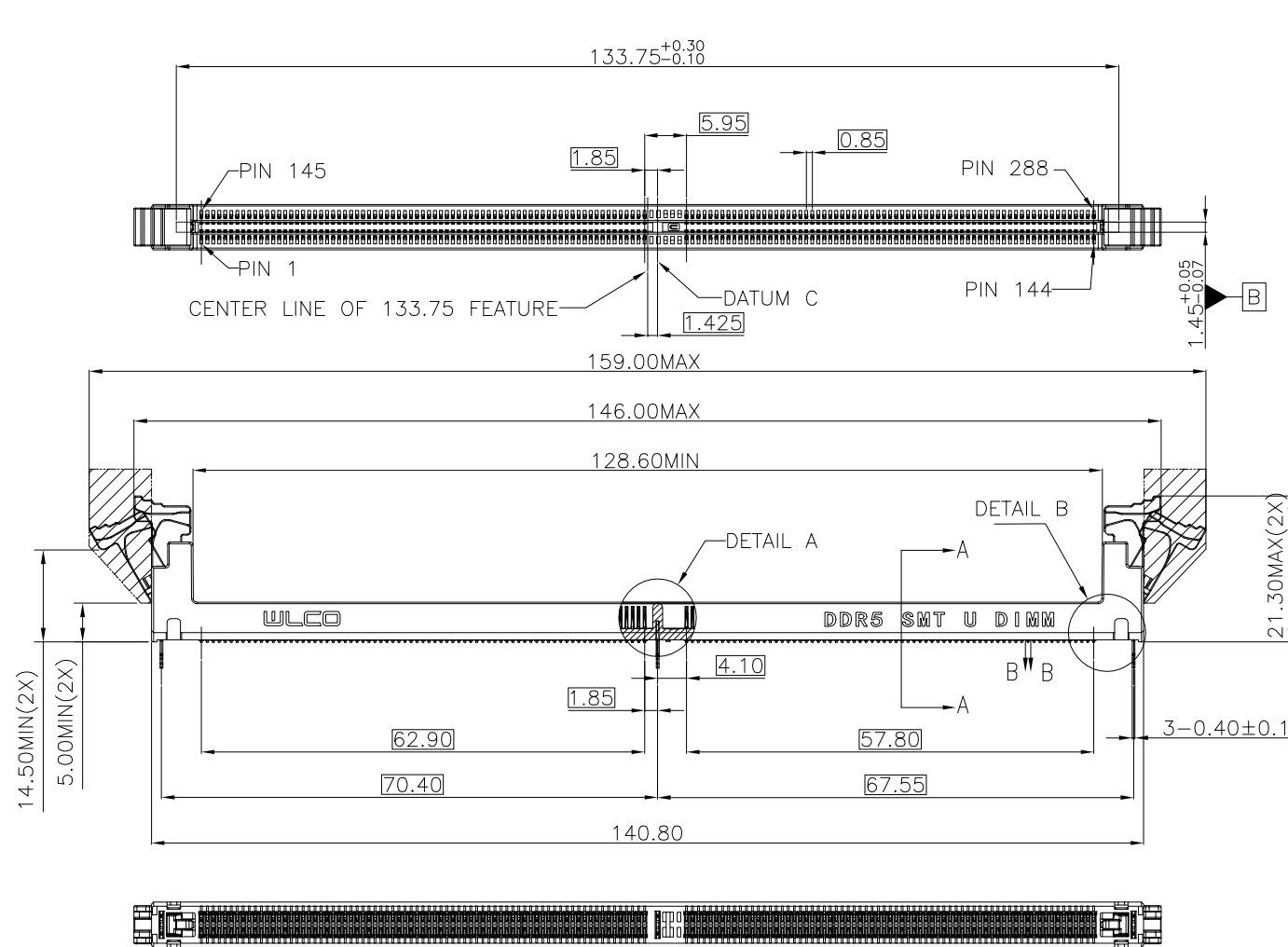

TOLERANCE	MODEL NAME: DDR5 288P SMT UDIMM DOUBLE LATCH TYPE	DRAWN: LongQiang.Peng
X.X ±0.35	MODEL NO: SEE TABLE	CHECKED: YouHua.Cai
X.XX ±0.25	UNIT: mm	APPROVED: YouHua.Cai
X.XXX ±0.10	SCALE: 1:1	DATE: 2021/03/01
ANGLE ±1.0°	REVISION: B	DWG NO: C-WLR5-288P01
	SHEET 1/5	FILE: C

WLCO 深圳市兴万联电子有限公司
SHENZHEN XING WAN LIAN ELECTRONICS CO., LTD.

RoHS GP HF

REV.	ECR/N NO.	DESCRIPTION	DRAWN	DATE
A	—	—	LongQiang	21/01/05
B	—	—	LongQiang	21/03/01

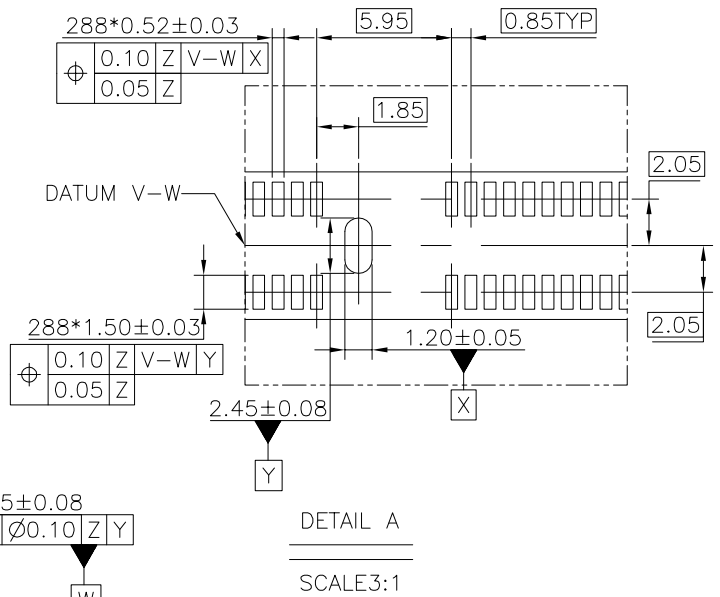
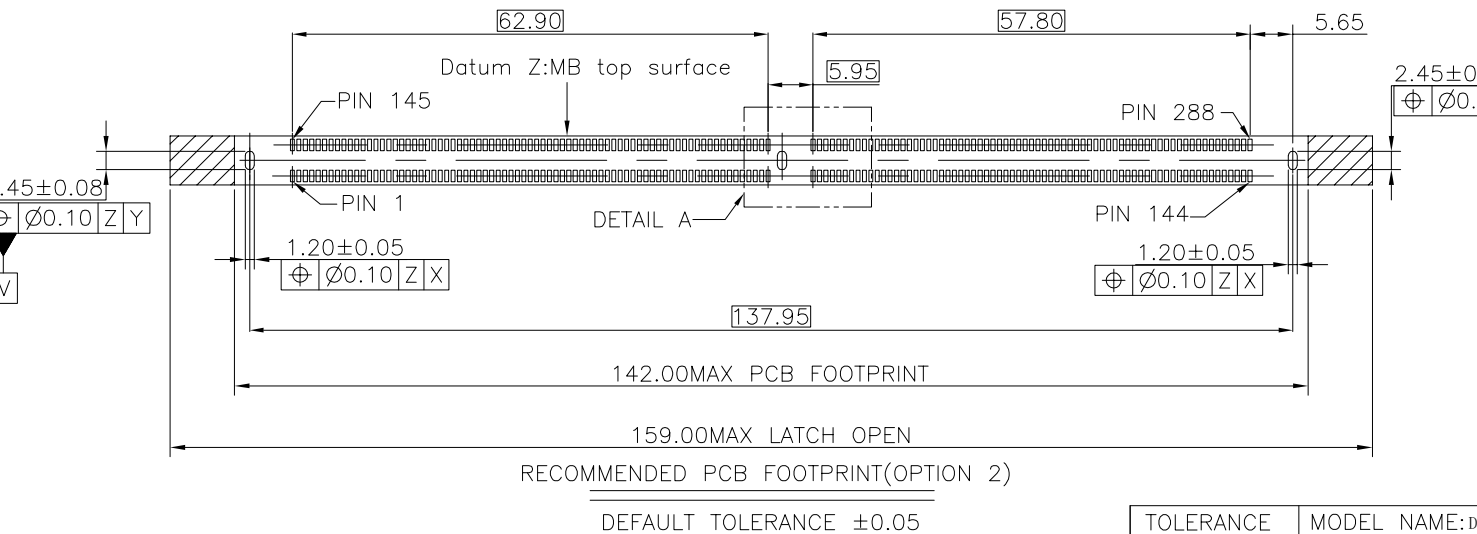
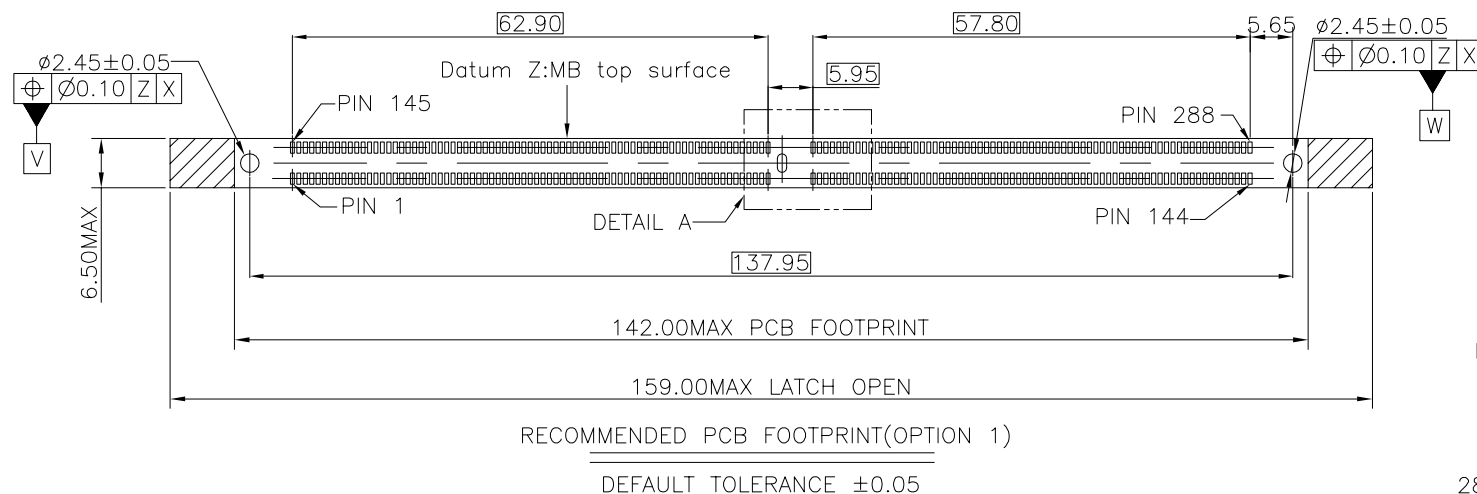

TOLERANCE		MODEL NAME:DDR5 288P SMT UDIMM DOUBLE LATCH TYPE				DRAWN: LongQiang.Peng	
X.X	±0.35	MODEL NO: SEE TABLE				CHECKED: YouHua.Cai	
X.XX	±0.25	UNIT:	SCALE:	REVISION:	SHEET	APPROVED: YouHua.Cai	
X.XXX	±0.10	mm	1:1	B	2/5	DATE: 2021/03/01	
ANGLE	±1.0°	DWG NO:C-WLR5-288P01				FILE: C	

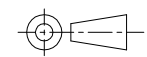

WLCO 深圳市兴万联电子有限公司
SHENZHEN XING WAN LIAN ELECTRONICS CO.,LTD.

RoHS GP HF

REV.	ECR/N NO.	DESCRIPTION	DRAWN	DATE
A	—	—	LongQiang	21/01/05
B	—	—	LongQiang	21/03/01

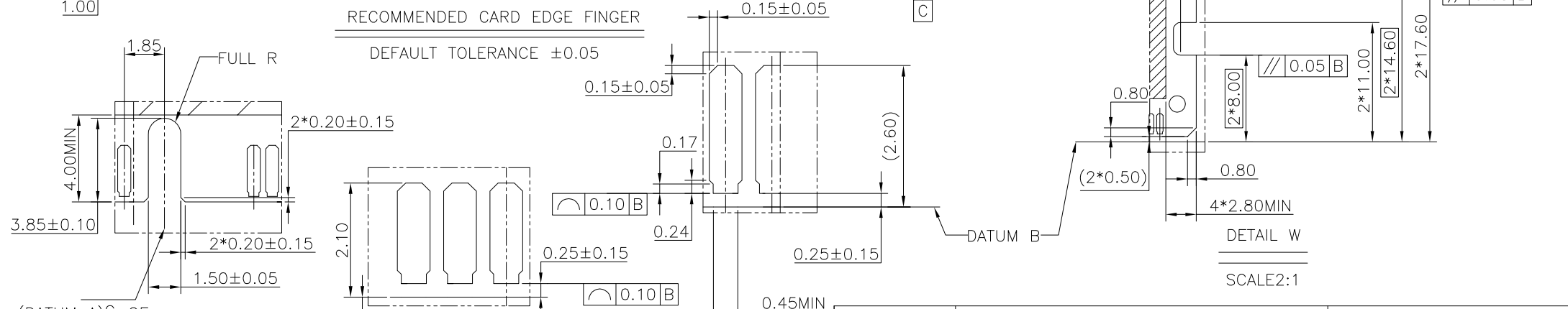
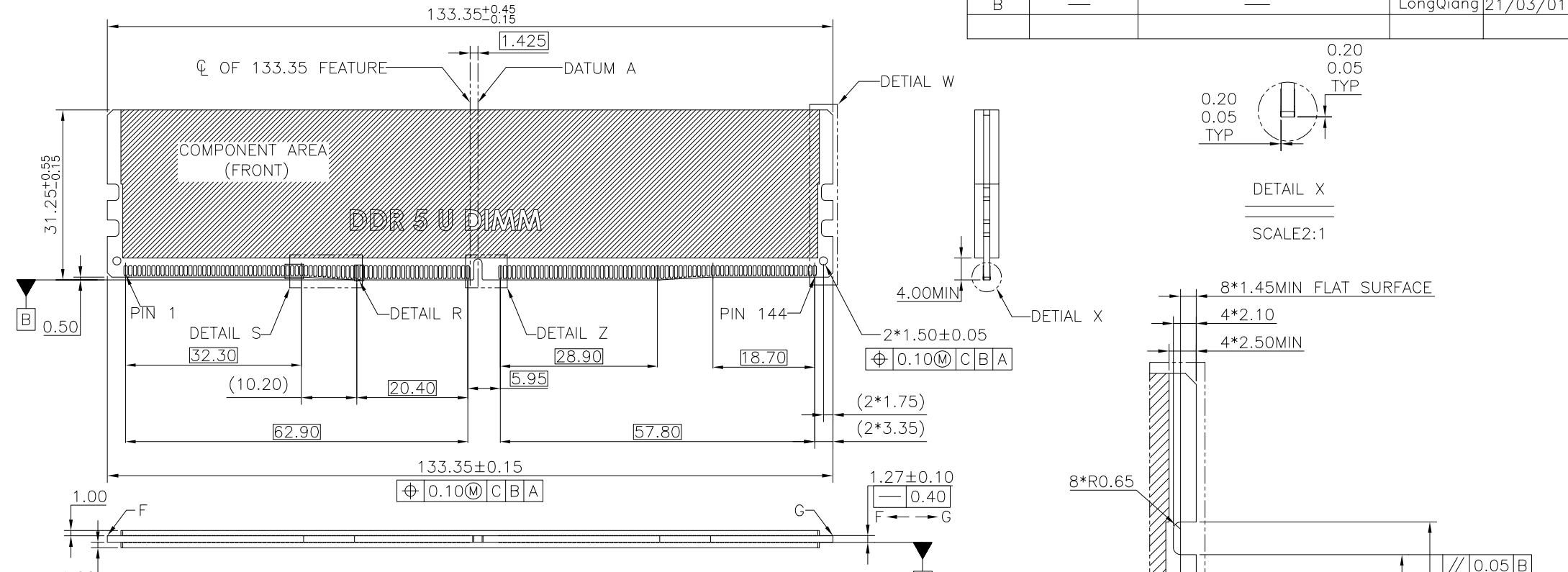

TOLERANCE	MODEL NAME: DDR5 288P SMT UDIMM DOUBLE LATCH TYPE				DRAWN:	LongQiang.Peng
X.X ±0.35	MODEL NO: SEE TABLE				CHECKED:	YouHua.Cai
X.XX ±0.25	UNIT:	SCALE:	REVISION:	SHEET	APPROVED:	YouHua.Cai
X.XXX ±0.10	mm	1:1	B	3/5	DATE:	2021/03/01
ANGLE ±1.0°	DWG NO: C-WLR5-288P01				FILE:	C

WLC0 深圳市兴万联电子有限公司
SHENZHEN XING WAN LIAN ELECTRONICS CO., LTD.

RoHS GP HF

REV.	ECR/N NO.	DESCRIPTION	DRAWN	DATE
A	—	—	LongQiang	21/01/05
B	—	—	LongQiang	21/03/01

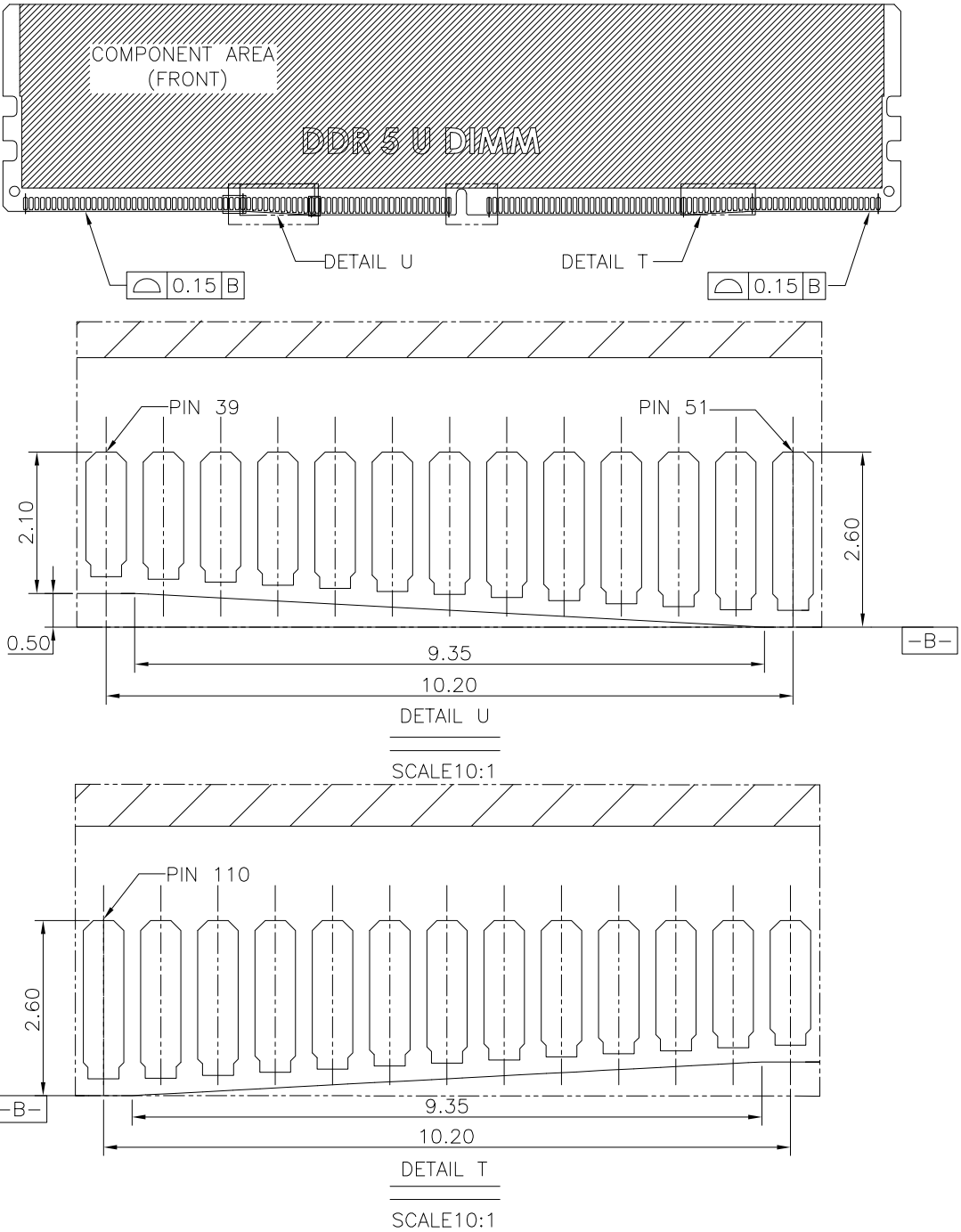

- NOTES:
- MATERIAL SPECIFICATION
 - HOUSING:HIGH TEMPERATURE THERMOPLASTIC,UL94-V0 V2 OR HB;
 - LATCH:HIGH TEMPERATURE THERMOPLASTIC,UL94-V0 V2 OR HB;
 - CONTACT:COPPER ALLOY;
 - HOOK:STEEL ALLOY OR STIANLESS STEEL OR COPPER ALLOY;
 - PLATING SPECIFICATION
 - CONTACT:
 - 50U" MIN NICKEL UNDERPLATED;
 - GOLD/NICKEL PLATING ON THE CONTACT AREA;
 - 100U" MIN MATTE TIN PLATING ON THE SOLDER AREA;
 - HOOK:
 - ONLY NICKEL PLATING;
 - OR NO PLATING;
 - OR 50U" MIN NICKEL UNDERPLATED,100U" MIN MATTE TIN ;
 - MECHANICAL PERFORMANCE
 - INSERTION FORCE-MODULE TO CONNECTOR:106.8N MAX;
 - INSERTION FORCE-CONNECTOR TO BOARD:35N MAX;
 - RETENTION FORCE:300gf/PIN MIN;
 - DURABILITY:25 CYCLES;
 - UNMATING FORCE(PER PIN PAIR):19.77N MIN;
 - ELECTRICAL PERFORMANCE
 - CURRENT RATING:1.0A PER PIN MAX;
 - VOLTAGE RATING:1.1V±0.1V;
 - LLCR:40mΩ MAX (INITIAL);
 - INSULATION RESISTANCE:500V DC,1MΩ MIN;
 - DIELECTRIC WITHSTAND VOLTAGE:500V AC,NO BREAK DOWN;
 - HSF COMPLIANT;
 - SMT SOLDERING PROCESS
 - SMT SOLDERING PEAK TEMPERATURE SHALL BE:260°C 10SECONDS.
 - THE LATCH SHALL BE CLOSED WHEN USED TO SOLDER;

TOLERANCE	MODEL NAME:DDR5 288P SMT UDIMM DOUBLE LATCH TYPE	DRAWN:	LongQiang.Peng
X.X ±0.35	MODEL NO: SEE TABLE	CHECKED:	YouHua.Cai
X.XX ±0.25	UNIT: SCALE: REVISION: SHEET	APPROVED:	YouHua.Cai
X.XXX ±0.10	mm 1:1 B 4/5	DATE:	2021/03/01
ANGLE ±1.0°	WLCO 深圳市兴万联电子有限公司 SHENZHEN XING WAN LIAN ELECTRONICS CO.,LTD.	DWG NO:C-WLR5-288P01	FILE: C

1 2 3 4 5 6 7 8

RoHS **GP** **HF**

REV.	ECR/N NO.	DESCRIPTION	DRAWN	DATE
A	—	—	LongQiang	21/01/05
B	—	—	LongQiang	21/03/01

TABLE

NO.	PART NO.	SPECIFICATION	HSF COMPLIANT
1	WLR5-001A	HOUSING_PA10T BLACK UL94-V0,LATCH_BLACK,CONTACT_C5191 15U Ni50u, HOOK_BRASS NICKEL PLATING.	RoHS COMPLIANT

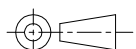
TOLERANCE X.X ±0.35 X.XX ±0.25 X.XXX ±0.10 ANGLE ±1.0°	MODEL NAME:DDR5 288P SMT UDIMM DOUBLE LATCH TYPE				DRAWN: LongQiang.Peng
	MODEL NO: SEE TABLE				CHECKED: YouHua.Cai
	UNIT:	SCALE:	REVISION:	SHEET	APPROVED: YouHua.Cai
	mm	1:1	B	5/5	DATE: 2021/03/01
		WLCO 深圳市兴万联电子有限公司 SHENZHEN XING WAN LIAN ELECTRONICS CO.,LTD.			DWG NO:C-WLR5-288P01
					FILE: C