

REV.	ECR/N NO.	DESCRIPTION	DRAWN	DATE
A			XiaoPeng	06/08-21
B			XiaoPeng	08/19-21

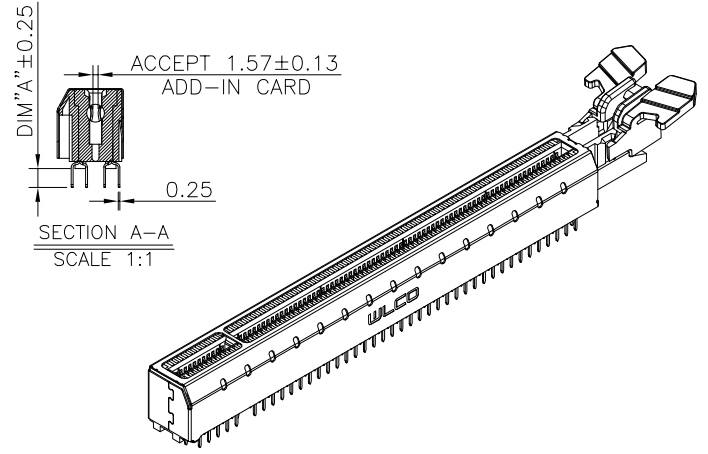
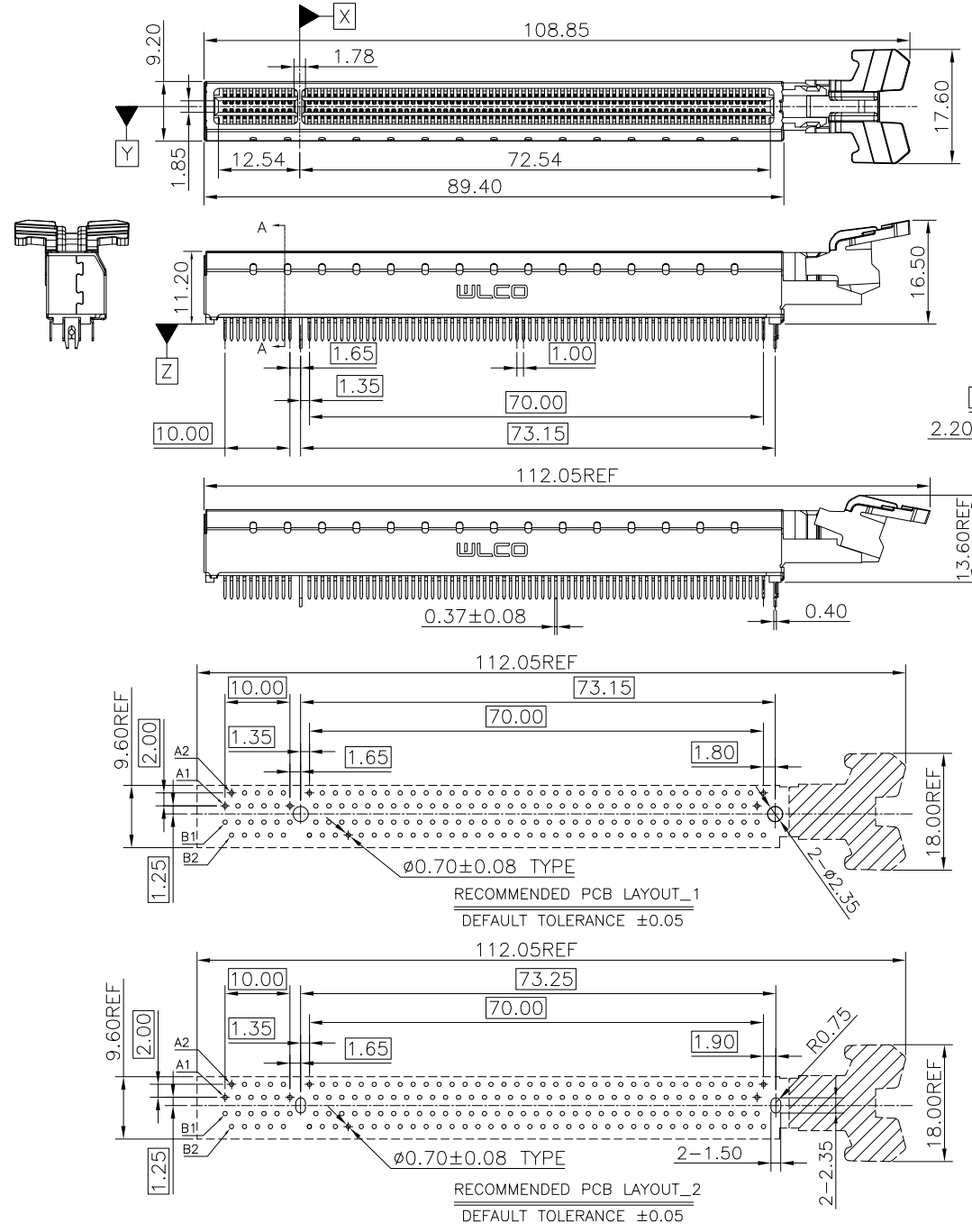

- NOTES:
- MATERIAL SPECIFICATION
 - 1-1.HOUSING:HIGH TEMPERATURE THERMOPLASTIC,UL94-V0 V2 OR HB;
 - 1-2.LATCH:HIGH TEMPERATURE THERMOPLASTIC,UL94-V0 V2 OR HB;
 - 1-3.CONTACT:COPPER ALLOY;
 - 1-4.HOOK:STEEL ALLOY OR STAINLESS ALLOY OR COPPER ALLOY;
 - 1-5.SHELL:STAINLESS;
 - PLATING SPECIFICATION
 - 2-1.CONTACT:
 - 50U" MIN NICKEL UNDERPLATED;
 - GOLD/NICKEL PLATING ON THE CONTACT AREA;
 - 100U" MIN MATTE TIN PLATING ON THE SOLDER AREA;
 - 2-2.HOOK:
 - ONLY NICKEL PLATING;
 - OR NO PLATING;
 - OR 50U MIN NICKEL UNDERPLATED,100U MIN MATTE TIN;
 - 2-3.SHELL:
 - NICKEL PLATING;
 - MECHANICAL PERFORMANCE
 - 3-1.INSERTION FORCE-MODULE TO CONNECTOR:1.15N MAX PER PAIR;
 - 3-2.DURABILITY:50 CYCLES;
 - 3-3.UNMATING FORCE(PER PIN PAIR):0.15N MIN;
 - ELECTRICAL PERFORMANCE
 - 4-1.CURRENT RATING:1.1A PER PIN MAX;
 - 4-2.LLCR:30mΩ MAX (INITIAL);
 - 4-3.INSULATION RESISTANCE:500V DC,1000MΩ MIN;
 - 4-4.DIELECTRIC WITHSTAND VOLTAGE:500V AC,0.5mA MAX;
 - HSF COMPLIANT

TOLERANCE		MODEL NAME:PCIE 164P AIRCRAFT BUCKLE WITH SHELL TYPE		DRAWN: XiaoPeng.Zhang	
X.X	±0.35	MODEL NO: SEE TABLE		CHECKED: YouHua.Cai	
X.XX	±0.25	UNIT:	SCALE:	REVISION:	SHEET
X.XXX	±0.10	mm	1:1	B	1/3
ANGLE	±1.0°	DATE: 2021/08/19		APPROVED: YouHua.Cai	
		DWG NO: CUS-WLPC-164P24		DATE: 2021/08/19	
		WLCO 深圳市兴万联电子有限公司 SHENZHEN XING WAN LIAN ELECTRONICS CO.,LTD.		FILE: C	

RoHS GP HF

REV.	ECR/N NO.	DESCRIPTION	DRAWN	DATE
A			XiaoPeng	06/08-21
B			XiaoPeng	08/19-21

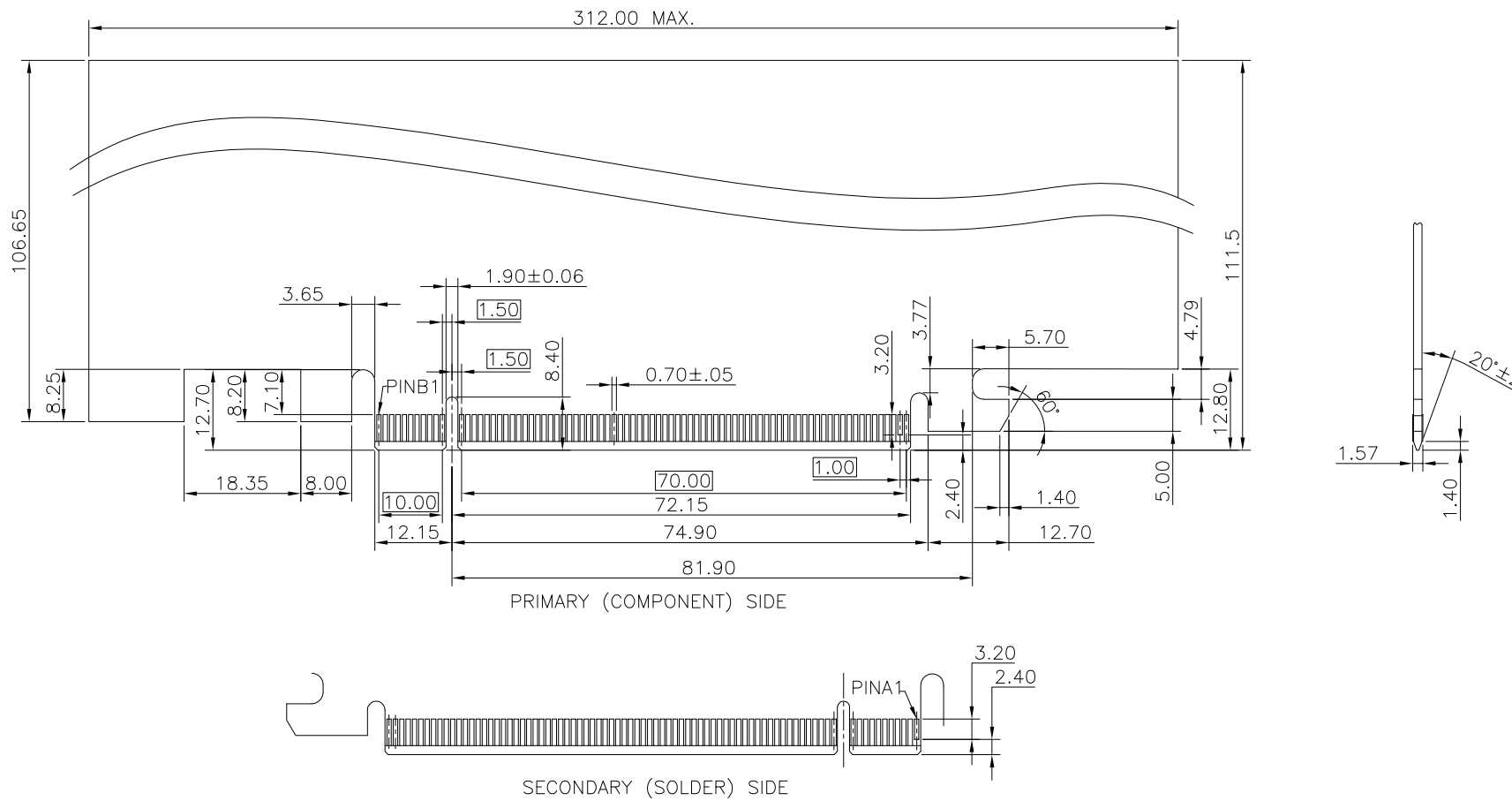

PRIMARY (COMPONENT) SIDE

SECONDARY (SOLDER) SIDE

RECOMMENDED CARD EDGE FINGER

DEFAULT TOLERANCE ±0.05

- NOTES:
1. NO TIE PERMITTED FROM CARD EDGE TO LEADING EDGE OF PAD FOR PINS 'A1' AND 'C'.
 2. CHAMFER EDGES MUST BE FREE OF CUTTING BURRS.

TOLERANCE	MODEL NAME:PCIE 164P AIRCRAFT BUCKLE WITH SHELL TYPE				DRAWN: XiaoPeng.Zhang	
X.X ±0.35	MODEL NO: SEE TABLE				CHECKED: YouHua.Cai	
X.XX ±0.25	UNIT:	SCALE:	REVISION:	SHEET	APPROVED: YouHua.Cai	
X.XXX ±0.10	mm	1:1	B	2/3	DATE: 2021/08/19	
ANGLE ±1.0°	 WLCO 深圳市兴万联电子有限公司 SHENZHEN XING WAN LIAN ELECTRONICS CO.,LTD.				DWG NO:CUS-WLPC-164P24	
					FILE: C	

RoHS GP HF

REV.	ECR/N NO.	DESCRIPTION	DRAWN	DATE
A	_____	_____	XiaoPeng	06/08-21
B	_____	_____	XiaoPeng	08/19-21

TABLE

NO.	PART NO.	SPECIFICATION	HSF COMPLIANT	DIM"A"
1	WLPC-127A	HOUSING_PA66 BLACK UL94-HB,LATCH_PA66 BLACK,CONTACT_C2680 G/F Ni50u,HOOK_STEEL ALLOY NICKEL PLATING,SHELL.	RoHS COMPLIANT	2.50mm

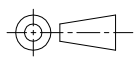
TOLERANCE X.X ±0.35 X.XX ±0.25 X.XXX ±0.10 ANGLE ±1.0°	MODEL NAME:PCIE 164P AIRCRAFT BUCKLE WITH SHELL TYPE				DRAWN: XiaoPeng.Zhang
	MODEL NO: SEE TABLE				CHECKED: YouHua.Cai
	UNIT:	SCALE:	REVISION:	SHEET	APPROVED: YouHua.Cai
	mm	1:1	B	3/3	DATE: 2021/08/19
		WLCO 深圳市兴万联电子有限公司 SHENZHEN XING WAN LIAN ELECTRONICS CO.,LTD.			DWG NO:CUS-WLPC-164P24
					FILE: C