

REV.	ECR/N NO.	DESCRIPTION	DRAWN	DATE
A	—	—	LongQiang	20/06/22
B	—	—	LongQiang	21/06/08

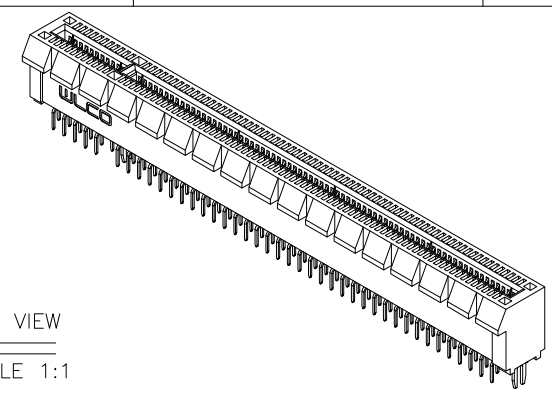

- NOTES:
- MATERIAL SPECIFICATION:
 - 1-1.HOUSING:HIGH TEMP THERMOPLASTIC UL94-V0 V2 OR HB;
 - 1-2.CONTACT:COPPER ALLOY;
 - 1-3.HOOK:STEEL ALLOY OR COPPER ALLOY;
 - PLATING SPECIFICATION:
 - 2-1.CONTACT: 50U NICKEL UNDERPLATED; GOLD/NICKEL PLATING ON CONTACT AREA; 100U MATTE TIN PLATING ON SOLDER AREA;
 - 2-2.HOOK: ONLY NICKEL PLATING; OR NO PLATING; OR 50U MIN NICKEL UNDERPLATED,100UMIN MATTE TIN;
 - MECHANICAL PERFORMANCE:
 - 3-1.INSERTION FORCE:1.15N MAX PER PIN PAIR;
 - 3-2.REMOVAL FORCE:0.15N MIN PER PIN PAIR;
 - 3-3.DURABILITY:50 CYCLES MIN;
 - ELECTRICAL PERFORMANCE:
 - 4-1.CURRENT RATING:1.1A PER PIN MIN;
 - 4-2.LLCR:30mΩ MAX(INITIAL);
 - 4-3.INSULATION RESISTANCE:1000MΩ MIN;
 - 4-4.DIELECTRIC WITHSTAND VOLTAGE:0.5mA MAX;
 - HSF COMPLIANT.
 - WAVE SOLDERING PROCESS
 - 6-1.RECOMMENDED CONDITION FOR WAVE SOLDERING:260±5°C AND IMMERSION DURATION 10±2 SECONDS.

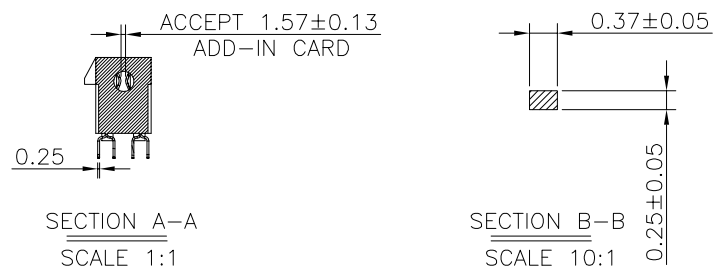
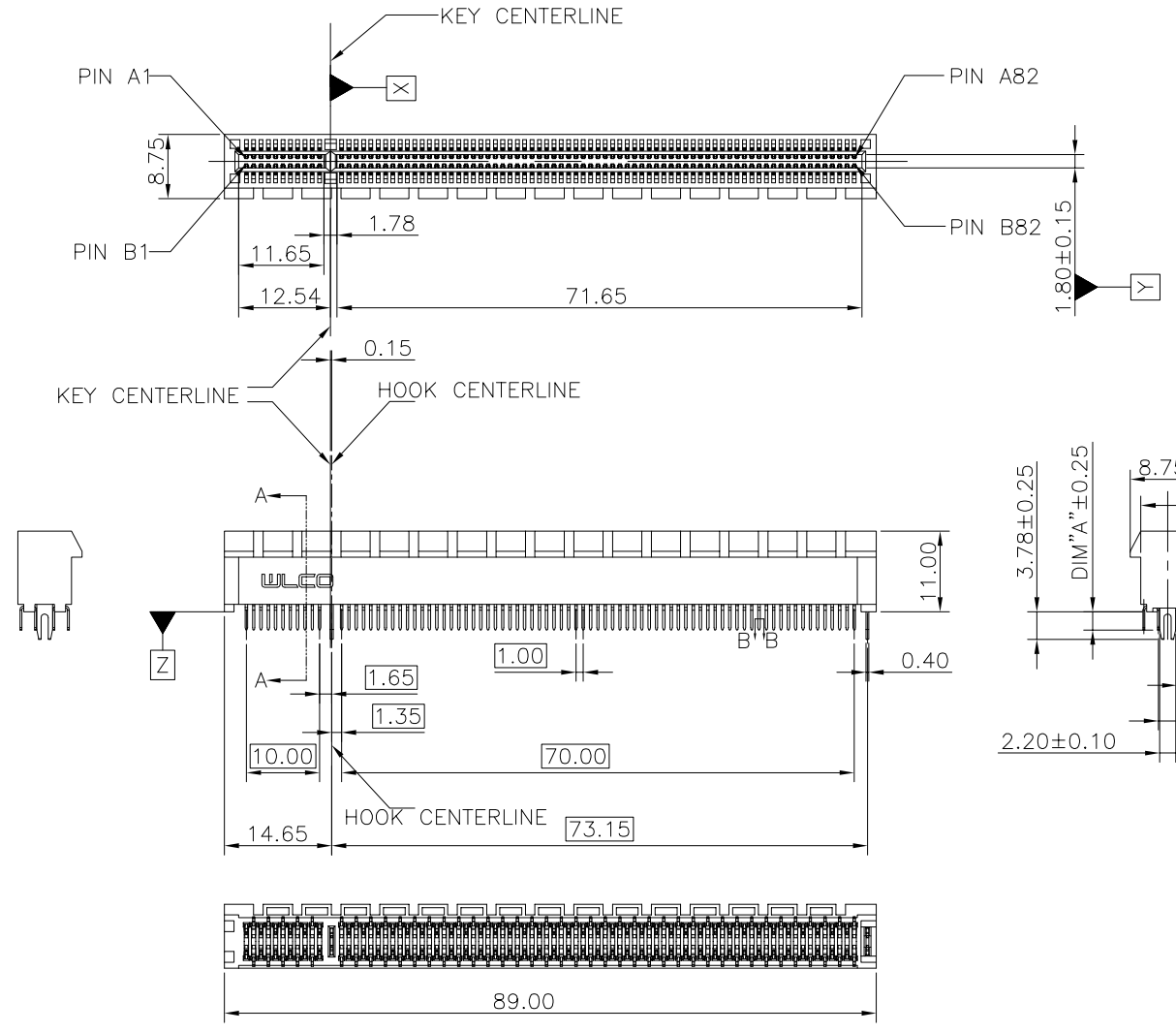

TOLERANCE X.X ±0.35 X.XX ±0.25 X.XXX ±0.10 ANGLE ±1.0°	MODEL NAME:PCIE 164P NO LATCH TYPE				DRAWN: LongQiang.Peng
	MODEL NO: SEE TABLE				CHECKED: YouHua.Cai
mm	UNIT:	SCALE:	REVISION:	SHEET	APPROVED: YouHua.Cai
		1:1	B	1/3	DATE: 2021/06/08
DWG NO:C-WLPC-164P13					FILE: C
深圳市兴万联电子有限公司 SHENZHEN XING WAN LIAN ELECTRONICS CO.,LTD.					

REV.	ECR/N NO.	DESCRIPTION	DRAWN	DATE
A	—	—	LongQiang	20/06/22
B	—	—	LongQiang	21/06/08

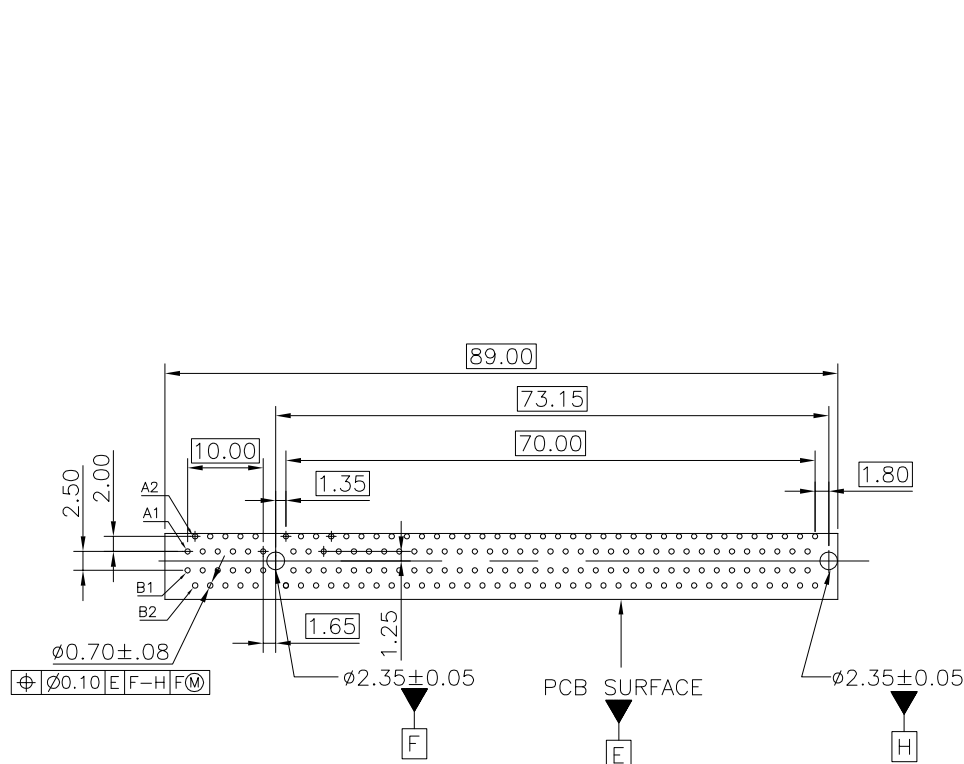

RECOMMENDED PCB LAYOUT
 DEFAULT TOLERANCE ± 0.05

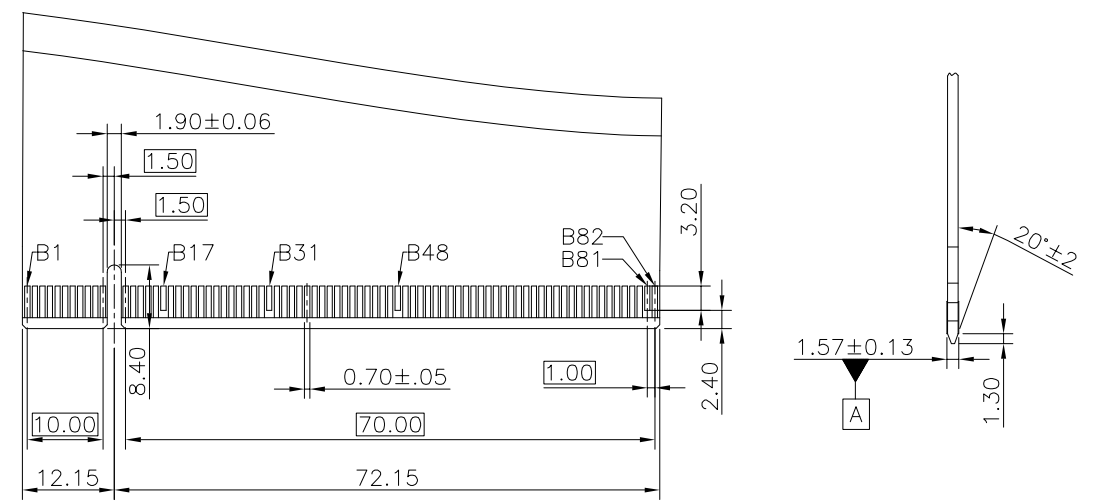

PRIMARY (COMPONENT) SIDE

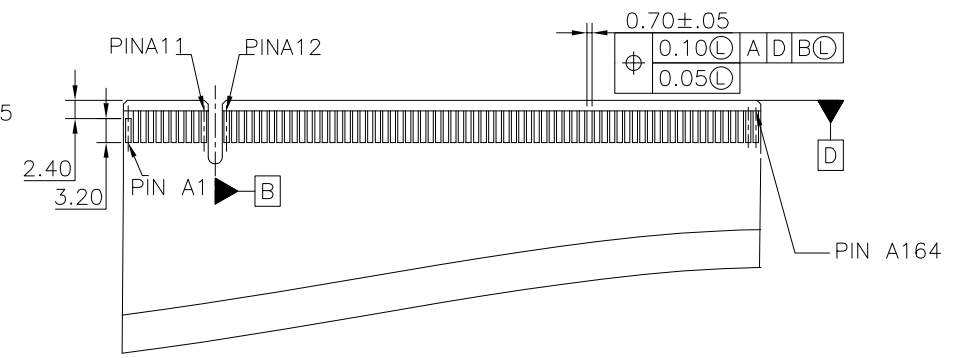

SECONDARY (SOLDER) SIDE

RECOMMENDED CARD EDGE FINGER
 DEFAULT TOLERANCE ± 0.05

- NOTES:
1. NO TIE PERMITTED FROM CARD EDGE TO LEADING EDGE OF PAD FOR PINS A1 AND 'C'.
 2. CHAMFER EDGES MUST BE FREE OF CUTTING BURRS.

TOLERANCE	MODEL NAME:PCIE 164P NO LATCH TYPE	DRAWN:	LongQiang.Peng
X.X ± 0.35	MODEL NO: SEE TABLE	CHECKED:	YouHua.Cai
X.XX ± 0.25	UNIT:	APPROVED:	YouHua.Cai
X.XXX ± 0.10	mm	DATE:	2021/06/08
ANGLE $\pm 1.0^\circ$	SCALE: 1:1	DWG NO:C-WLPC-164P13	FILE: C
	REVISION: B		
	SHEET 2/3		

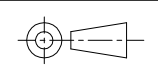

WLCOP 深圳市兴万联电子有限公司
 SHENZHEN XING WAN LIAN ELECTRONICS CO.,LTD.

RoHS GP HF

REV.	ECR/N NO.	DESCRIPTION	DRAWN	DATE
A	—	—	LongQiang	20/06/22
B	—	—	LongQiang	21/06/08

TABLE

NO.	PART NO.	SPECIFICATION	HSF COMPLIANT	DIM"A"
1	WLPC-113D	HOUSING_PA66 BLUE UL94-V0,CONTACT_C2680 G/F Ni50u,HOOK_STEEL ALLOY NICKEL PLATING.	RoHS COMPLIANT	2.50mm

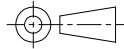
TOLERANCE X.X ±0.35 X.XX ±0.25 X.XXX ±0.10 ANGLE ±1.0°	MODEL NAME:PCIE 164P NO LATCH TYPE				DRAWN: LongQiang.Peng	
	MODEL NO: SEE TABLE				CHECKED: YouHua.Cai	
	UNIT:	SCALE:	REVISION:	SHEET	APPROVED: YouHua.Cai	
	mm	1:1	B	3/3	DATE: 2021/06/08	
				WLCO 深圳市兴万联电子有限公司 SHENZHEN XING WAN LIAN ELECTRONICS CO.,LTD.		DWG NO:C-WLPC-164P13 FILE: C