

REV.	ECR/N NO.	DESCRIPTION	DRAWN	DATE
A	_____	_____	LongQiang	20/06/21
B	_____	_____	LongQiang	20/07/22
C	_____	_____	XiaoPeng	21/04/20

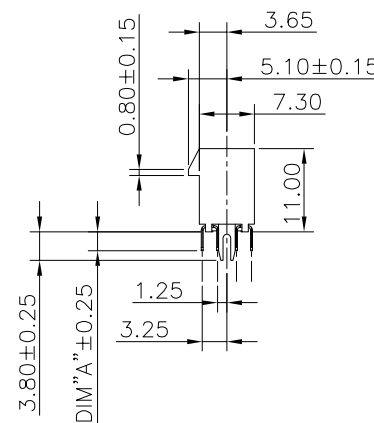

NOTES:

- MATERIAL SPECIFICATION:
  - 1-1.HOUSING:HIGH TEMP THERMOPLASTIC UL94-V0 V2 OR HB;
  - 1-2.CONTACT:COPPER ALLOY;
  - 1-3.HOOK:STEEL ALLOY;
- PLATING SPECIFICATION:
  - 2-1.CONTACT: 50U NICKEL UNDERPLATED; GOLD/NICKEL PLATING ON CONTACT AREA; 100U MATTE TIN PLATING ON SOLDER AREA;
  - 2-2.HOOK: ONLY NICKEL PLATING; OR NO PLATING; OR 50U MIN NICKEL UNDERPLATED,100UMIN MATTE TIN;
- MECHANICAL PERFORMANCE:
  - 3-1.INSERTION FORCE:1.15N MAX PER PIN PAIR;
  - 3-2.REMOVAL FORCE:0.15N MIN PER PIN PAIR;
  - 3-3.DURABILITY:50 CYCLES MIN;
- ELECTRICAL PERFORMANCE:
  - 4-1.CURRENT RATING:1.1A PER PIN MIN;
  - 4-2.LLCCR:30mΩ MAX(INITIAL);
  - 4-3.INSULATION RESISTANCE:1000MΩ MIN;
  - 4-4.DIELECTRIC WITHSTAND VOLTAGE:0.5mA MAX;
- HSF COMPLIANT.
- WAVE SOLDERING PROCESS
  - 6-1.RECOMMENDED CONDITION FOR WAVE SOLDERING:260±5°C AND IMMERSION DURATION 10±2 SECONDS.

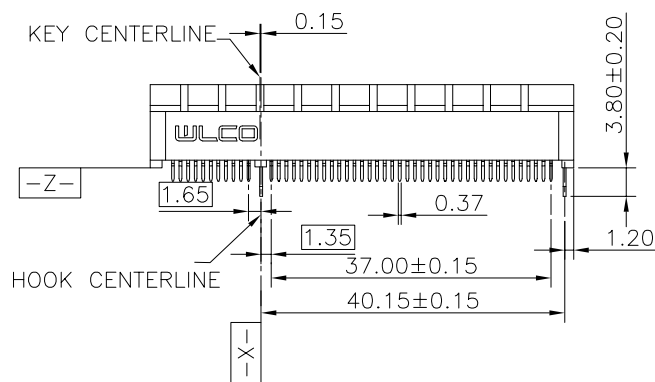
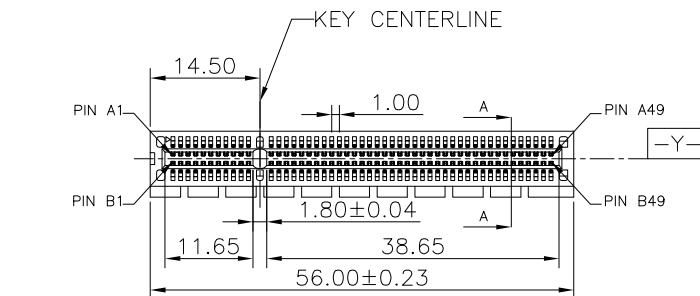
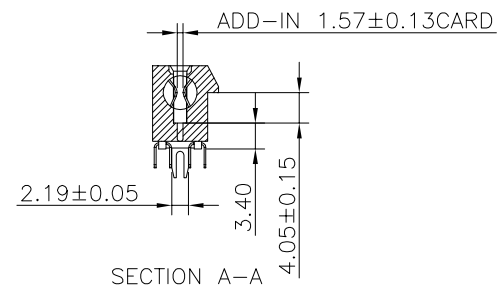
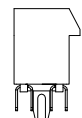

TOLERANCE	MODEL NAME:PCIE 98PIN DOUBLE HOOK TYPE				DRAWN:	XiaoPeng.Zhang
X.X ±0.35	MODEL NO: SEE TABLE				CHECKED:	YouHua.Cai
X.XX ±0.25	UNIT:	SCALE:	REVISION:	SHEET	APPROVED:	YouHua.Cai
X.XXX ±0.10	mm	1:1	C	1/3	DATE:	2021/04/20
ANGLE ±1.0°	<b>WLCO</b> 深圳市兴万联电子有限公司 SHENZHEN XING WAN LIAN ELECTRONICS CO.,LTD.				DWG NO:	C-WLPC-98P03
					FILE:	C

REV.	ECR/N NO.	DESCRIPTION	DRAWN	DATE
A	_____	_____	LongQiang	20/06/21
B	_____	_____	LongQiang	20/07/22
C	_____	_____	XiaoPeng	21/04/20

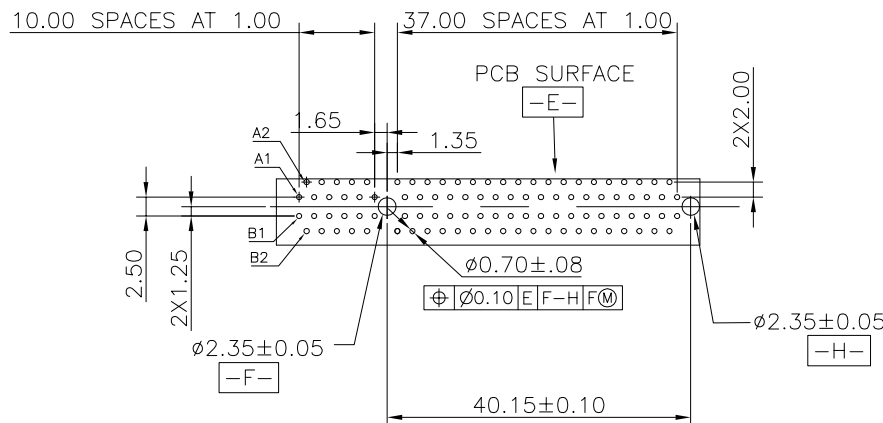

RECOMMENDED PCB LAYOUT  
DEFAULT TOLERANCE ±0.05

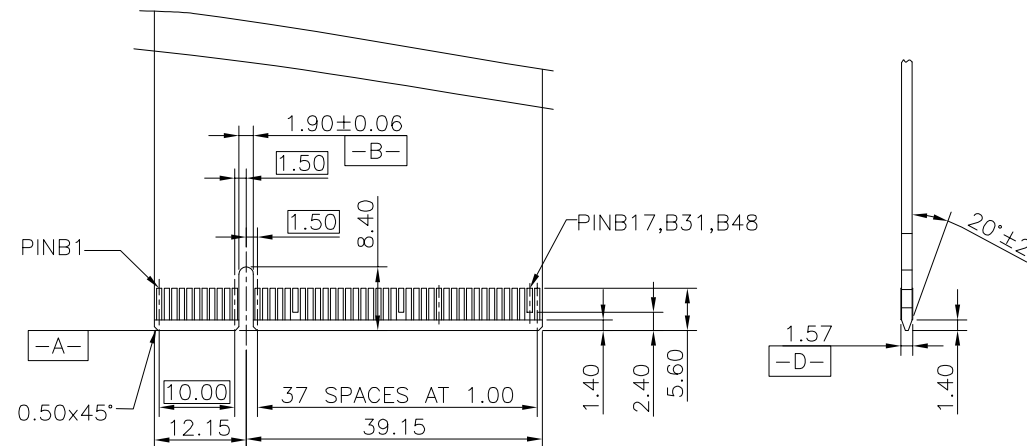

PRIMARY (COMPONENT) SIDE

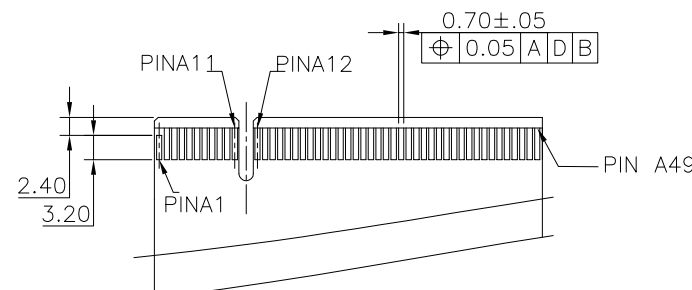

SECONDARY (SOLDER) SIDE  
RECOMMENDED CARD EDGE FINGER

DEFAULT TOLERANCE ±0.05

NOTES:

- NO TIE PERMITTED FROM CARD EDGE TO LEADING EDGE OF PAD FOR PINS A1 AND 'C'.
- CHAMFER EDGES MUST BE FREE OF CUTTING BURRS.

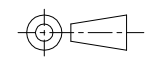
TOLERANCE	MODEL NAME:PCIE 98PIN DOUBLE HOOK TYPE				DRAWN:	XiaoPeng.Zhang
X.X ±0.35	MODEL NO: SEE TABLE				CHECKED:	YouHua.Cai
X.XX ±0.25	UNIT:	SCALE:	REVISION:	SHEET	APPROVED:	YouHua.Cai
X.XXX ±0.10	mm	1:1	C	2/3	DATE:	2021/04/20
ANGLE ±1.0°	DWG NO:C-WLPC-98P03				FILE:	C
 <b>WLCO</b> 深圳市兴万联电子有限公司 SHENZHEN XING WAN LIAN ELECTRONICS CO.,LTD.						

RoHS GP HF

REV.	ECR/N NO.	DESCRIPTION	DRAWN	DATE
A	_____	_____	LongQiang	20/06/21
B	_____	_____	LongQiang	20/07/22
C	_____	_____	XiaoPeng	21/04/20

TABLE

NO.	PART NO.	SPECIFICATION	HSF COMPLIANT	DIM"A"
1	WLPC-026A	HOUSING_PA66 BLACK UL94-HB,CONTACT_C2680 G/F Ni50u,HOOK_STEEL ALLOY NICKEL PLATING.	RoHS COMPLIANT	2.50mm

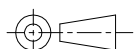
TOLERANCE X.X ±0.35 X.XX ±0.25 X.XXX ±0.10 ANGLE ±1.0°	MODEL NAME:PCIE 98PIN DOUBLE HOOK TYPE				DRAWN: XiaoPeng.Zhang
	MODEL NO: SEE TABLE				CHECKED: YouHua.Cai
	UNIT:	SCALE:	REVISION:	SHEET	APPROVED: YouHua.Cai
	mm	1:1	C	3/3	DATE: 2021/04/20
		<b>WLCO</b> 深圳市兴万联电子有限公司 SHENZHEN XING WAN LIAN ELECTRONICS CO.,LTD.			DWG NO:C-WLPC-98P03
					FILE: C