

RoHS GP HF

REV.	ECR/N NO.	DESCRIPTION	DRAWN	DATE
C	_____	_____	LongQiang	20/03/25
D	_____	_____	LongQiang	20/04/20
E	_____	_____	LongQiang	21/04/15

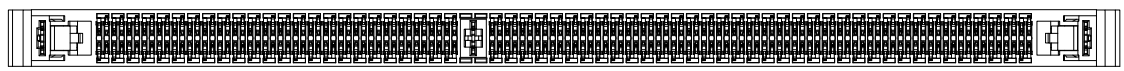
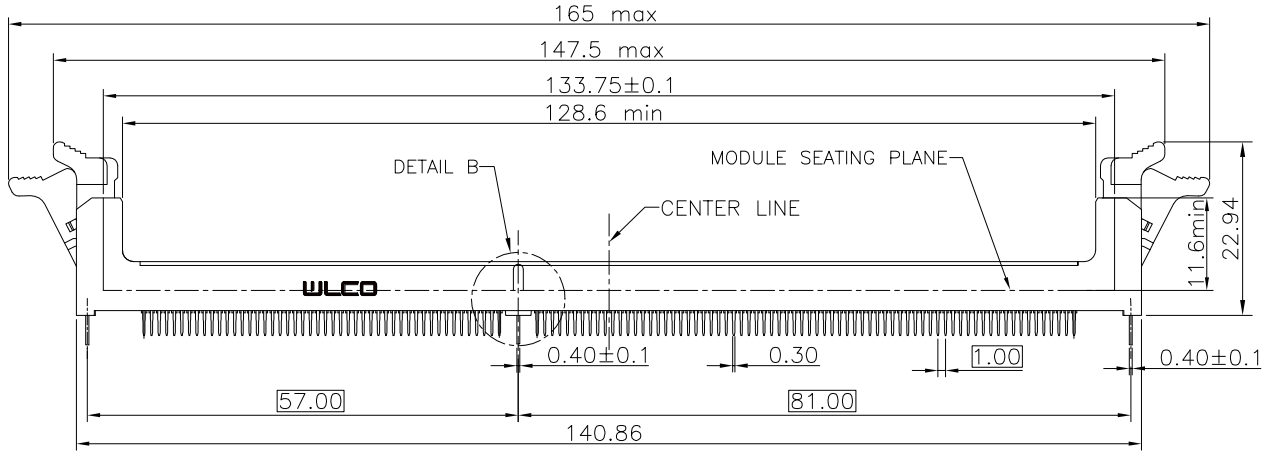
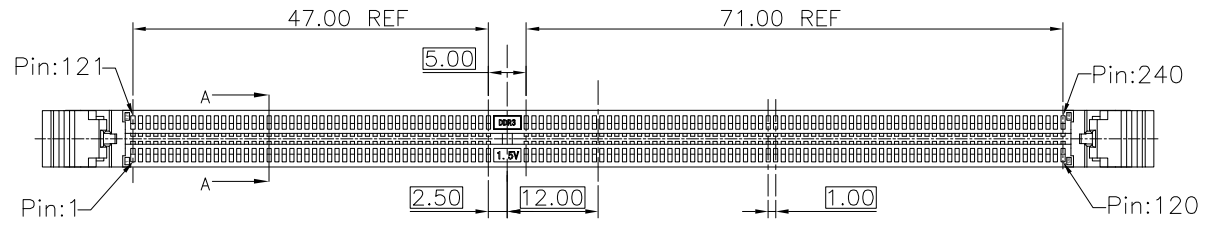

1. Materials.
  - 1.1 Housing: High Temp Thermoplastic UL94-V0 V2 OR HB
  - 1.2 Contact: Copper alloy
  - 1.3 Latch: High Temp Thermoplastic UL94-V0 V2 OR HB
  - 1.4 Hook: Copper alloy OR Steel alloy OR Stainless
2. Finish
  - 2.1 Contact :
    - 50u"min nickel under plated;
    - gold/nickel plating on contact area;
    - 100u"min Matte Tin plating on solder area.
  - 2.2 Hook:
    - 50u"min Nickel under plated and 100u"min Matte Tin or only Nickel plating or no plating.
3. Specification
  - 3.1 Current Rating: 0.5A(max)
  - 3.2 Dielectric Withstanding Voltage: 500V AC min
  - 3.3 Contact Resistance: 30 Milliohms max
  - 3.4 Insulation Resistance: 1000 Megohms min
  - 3.5 Contact Retention Force: 0.3kgf min per pin
  - 3.6 Insertion Force: 10.89kgf max
  - 3.7 Withdrawal Force: 1.68kgf min
  - 3.8 Durability : 25 cycles min
  - 3.9 Operating Temperature: -55° C to +85° C

TOLERANCE X.X ±0.35 X.XX ±0.25 X.XXX ±0.10 ANGLE ±1.0°	MODEL NAME:DDR3 240PIN (3.3 HEIGHT ) WIDE LATCH TYPE				DRAWN: LongQiang.Peng	
	MODEL NO: SEE TABLE				CHECKED: LongQiang.Peng	
	UNIT:	SCALE:	REVISION:	SHEET	APPROVED: YouHua.Cai	
	mm	1:1	E	1/4	DATE: 2021/04/15	
WLCOP 深圳市兴万联电子有限公司 SHENZHEN XING WAN LIAN ELECTRONICS CO.,LTD.		DWG NO: CUS-WLDD-R306				FILE: C

RoHS GP HF

REV.	ECR/N NO.	DESCRIPTION	DRAWN	DATE
C			LongQiang	20/03/25
D			LongQiang	20/04/20
E			LongQiang	21/04/15

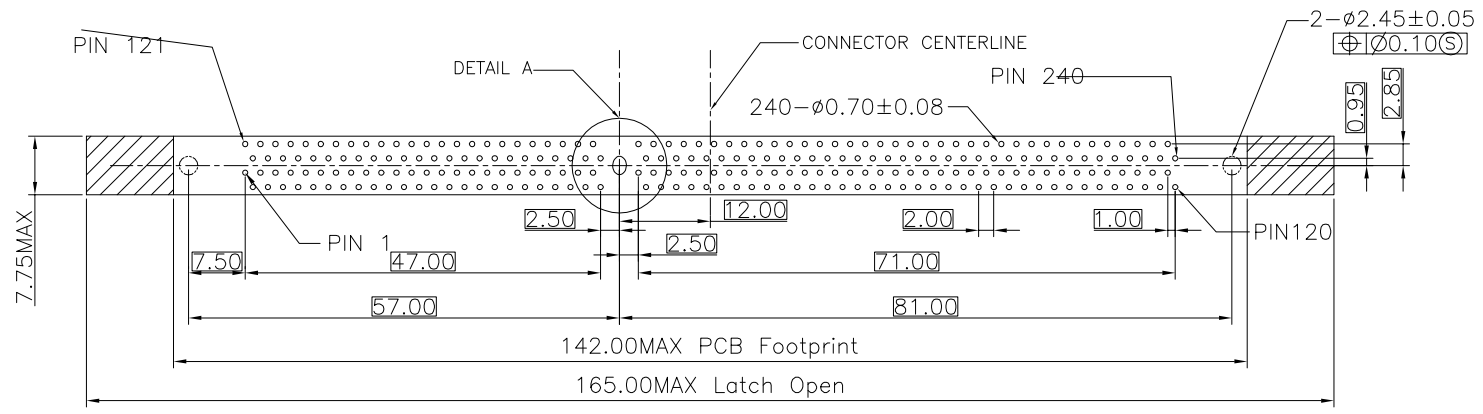
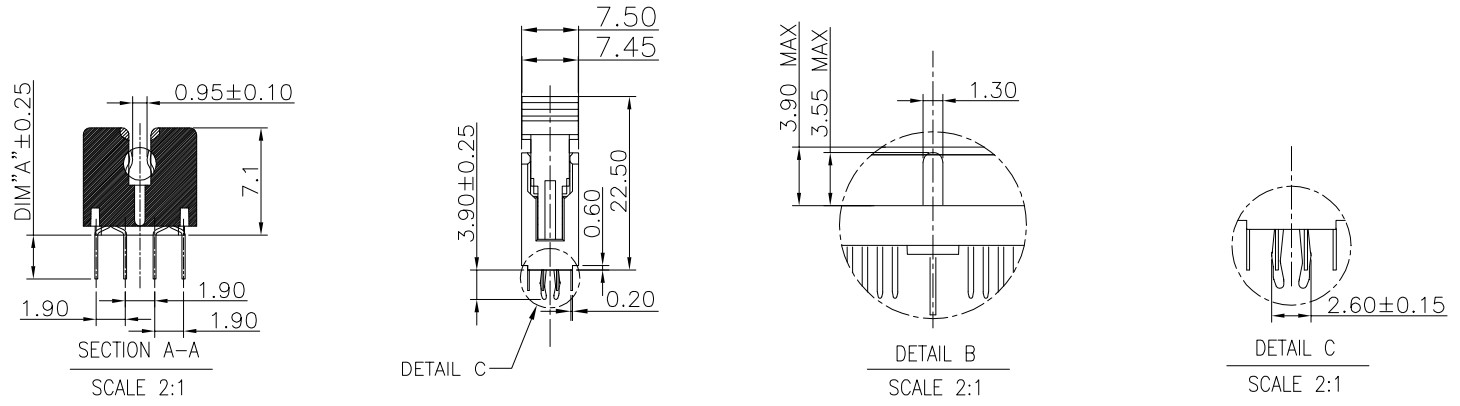

RECOMMENDED PC BOARD HOLE LAYOUT

TOLERANCE X.X ±0.35 X.XX ±0.25 X.XXX ±0.10 ANGLE ±1.0°	MODEL NAME:DDR3 240PIN (3.3 HEIGHT ) WIDE LATCH TYPE				DRAWN: LongQiang.Peng
	MODEL NO: SEE TABLE				CHECKED: LongQiang.Peng
	UNIT:	SCALE:	REVISION:	SHEET	APPROVED: YouHua.Cai
	mm	1:1	E	2/4	DATE: 2021/04/15
深圳市兴万联电子有限公司 SHENZHEN XING WAN LIAN ELECTRONICS CO.,LTD.				DWG NO:CUS-WLDD-R306	FILE: C

RoHS GP HF

REV.	ECR/N NO.	DESCRIPTION	DRAWN	DATE
C			LongQiang	20/03/25
D			LongQiang	20/04/20
E			LongQiang	21/04/15

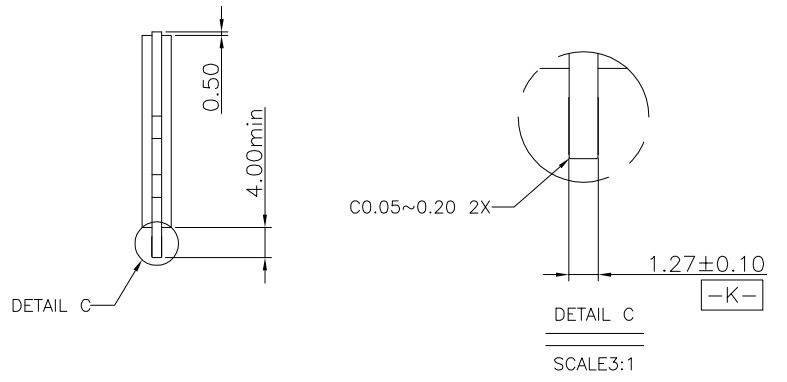
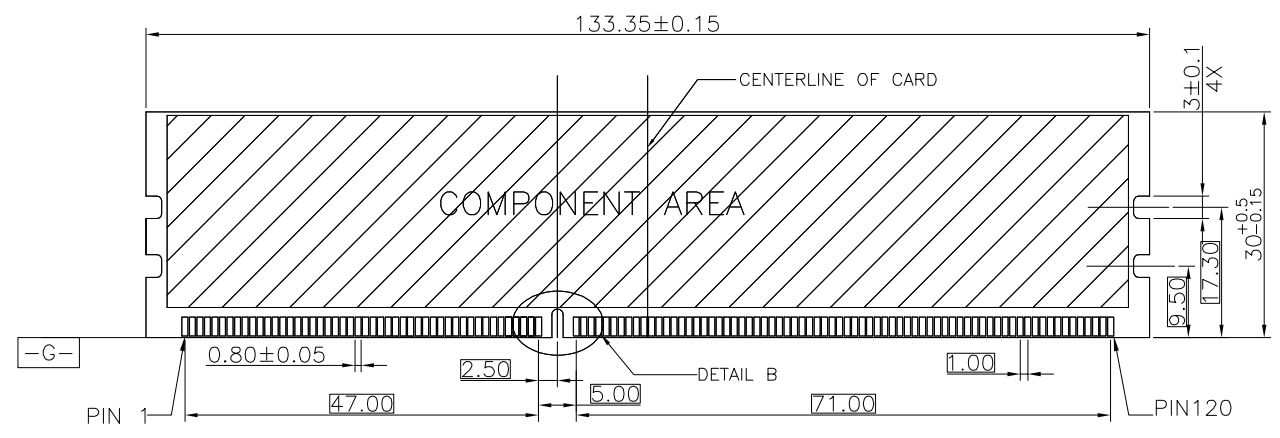

RECOMMENDED MODULE LAYOUT

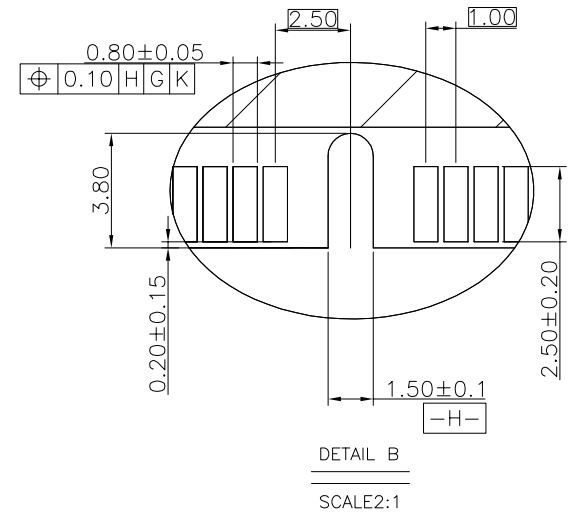
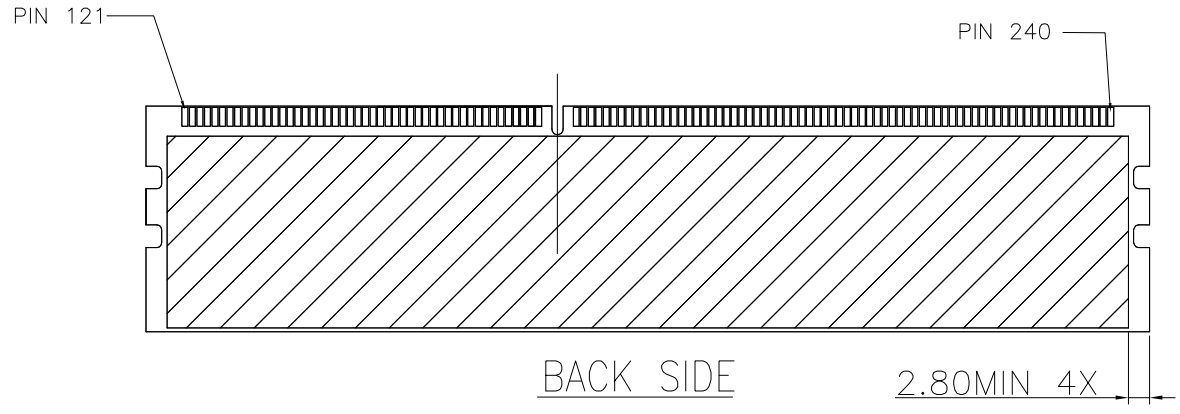

TOLERANCE	MODEL NAME:DDR3 240PIN (3.3 HEIGHT) WIDE LATCH TYPE	DRAWN:	LongQiang.Peng
X.X ±0.35	MODEL NO: SEE TABLE	CHECKED:	LongQiang.Peng
X.XX ±0.25	UNIT: mm	APPROVED:	YouHua.Cai
X.XXX ±0.10	SCALE: 1:1	DATE:	2021/04/15
ANGLE ±1.0°	REVISION: E	DWG NO:	CUS-WLDD-R306
	SHEET 3/4	FILE:	C

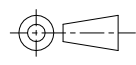

**WLCO** 深圳市兴万联电子有限公司  
SHENZHEN XING WAN LIAN ELECTRONICS CO., LTD.

1 2

**RoHS** **GP** **HF**

REV.	ECR/N NO.	DESCRIPTION	DRAWN	DATE
C	_____	_____	LongQiang	20/03/25
D	_____	_____	LongQiang	20/04/20
E	_____	_____	LongQiang	21/04/15

A

TABLE

NO.	PART NO.	SPECIFICATION	HSF COMPLIANT	DIM"A"
1	WLDD-085A	HOUSING_PA66 BLACK UL94 HB, LATCH_PA66 WHITE, CONTACT_C2680 G/F Ni50u, HOOK_STEEL ALLOY NICKEL PLATING.	RoHS COMPLIANT	2.70mm

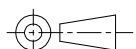
<p>TOLERANCE</p> <p>X.X ±0.35</p> <p>X.XX ±0.25</p> <p>X.XXX ±0.10</p> <p>ANGLE ±1.0°</p>	MODEL NAME:DDR3 240PIN (3.3 HEIGHT ) WIDE LATCH TYPE				DRAWN: LongQiang.Peng	
	MODEL NO: SEE TABLE				CHECKED: LongQiang.Peng	
	UNIT:	SCALE:	REVISION:	SHEET	APPROVED: YouHua.Cai	
	mm	1:1	E	4/4	DATE: 2021/04/15	
	<p><b>WLCO</b> 深圳市兴万联电子有限公司</p> <p>SHENZHEN XING WAN LIAN ELECTRONICS CO.,LTD.</p>				DWG NO:CUS-WLDD-R306	
					FILE: C	

1 2 3 4 5 6 7 8